

TOSHIBA

GR-200 Series
GBU 200
Bay Control IED



GR-200 series -

The GR-200 Series is Toshiba's next generation of protection and control IED's, designed for transmission/distribution networks and providing a platform for distributed and renewable energy systems and railway applications. Flexible adaptation is enabled using extensive hardware and modular software combinations facilitating an application oriented solution.

Meeting your needs -

Extensive hardware and modular software combinations provide the flexibility to meet your application and engineering requirements.

Future upgrade paths and minor modifications are readily achievable on demand.

Powerful and wide application -

In addition to protection & control, GR-200 has been designed to meet the challenges and take advantage of developments in information & communications technology.

APPLICATION

GBU200 bay control is implemented on Toshiba's next generation GR-200 series IED platform and has been designed to provide bay control and protection applications for transmission lines and distribution feeders in all types of network. This powerful and user-friendly IED will provide you with the flexibility to meet your application and engineering requirements in addition to offering good performance, the high quality and operational peace of mind.

- Control and monitoring of switchgear, transformers and other equipment or devices in EHV, HV, MV and LV substations
- Built-in feeder protection functions
- Applicable to single, double and one- and a half breaker arrangements and to both GIS and AIS switchgear
- Various models and hardware options for flexible application depending on system requirement and controlled object
- Communications within substation automation system, IEC 61850-8-1 [Station bus], IEC 60870-5-103 and IEC 62439/PRP/HSR

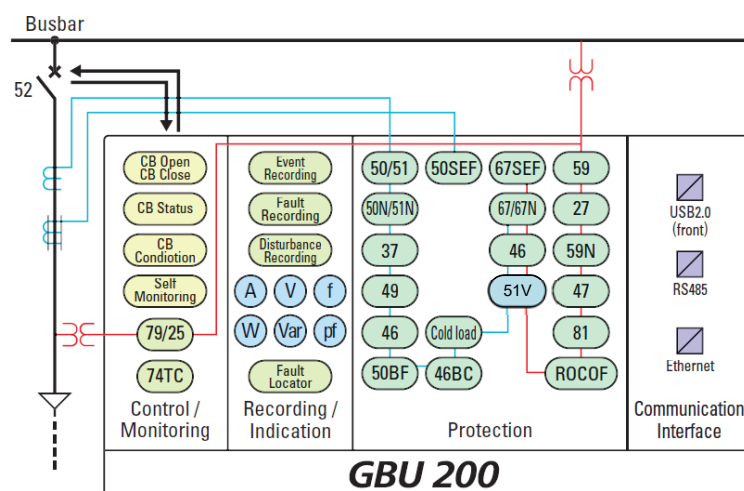

FEATURES

• Application

- For control and monitoring of switchgear, transformers and other equipment or devices in EHV, HV, MV and LV substations
- Built-in feeder protection functions
- Applicable to single, double and one- and a half breaker arrangements and to both GIS and AIS switchgear

• Functionality

- Synchronization check and dead-line check function for single- or multi-breaker arrangements
- Analog measurement accuracy up to 0.5% for power, current and voltage
- Power quality measurement and monitoring (option)
- Integrated disturbance and event recorder
- Time synchronization
- Self-supervision
- Parameters with password protection
- Simulation and test functions for communication, control and protection

• Communication

- System interface - RS485, Fiber optic, 100BASE-TX/1000BASE-T, 100BASE-FX, 1000BASE-LX
- Multi protocol - IEC 60870-5-103, IEC 61850 and IEC 62439/PRP/HSR

• Security

- Password protection

• Flexibility

- Various models and hardware options for flexible application depending on system requirement and controlled object
- Programmable control, trip and alarm logic with PLC tool software
- Simple engineering on configurable function-base platform

• Human Machine Interface

- Graphical LCD and 26 LEDs
- 7 configurable function keys
- USB port for local PC connection
- Direct control buttons for open/close (O/I) and control authority (43R/L)
- Help key for supporting operation
- Monitoring terminals for testing

FUNCTIONS

• Control

- Circuit breaker and isolator control
- Switchgear interlock check
- Transformer tap change control
- Synchronism voltage check
- Autoreclose (upto 5 shot)
- Programmable automatic sequence control
- Manual override

• Monitoring

- Status and condition monitoring of primary apparatus
- Switchgear operation monitoring
- Plausibility check
- Measurement of I, V, P, Q, PF, f, Wh and varh
- Measurement and supervision of individual and total harmonic up to 15th, sag, swell, interruption (option)

- DC analog input (for transducer input)
- DC analog output (for transducer output)
- Current and voltage circuit supervision
- Trip circuit supervision
- Fault locator

• Protection

- Directional or non-directional overcurrent and earth fault protection
- Sensitive directional or non-directional earth fault protection
- Directional or non-directional negative sequence overcurrent protection
- Undercurrent protection
- Negative sequence overvoltage protection
- Thermal overload protection
- Under- and over-voltage protection
- Under- and over-frequency protection
- Rate-of-change of frequency

- Broken conductor detection
- Circuit breaker fail
- Cold load protection
- High-impedance differential protection
- Switch-on-to fault protection
- Voltage controlled overcurrent
- Inrush current detection (2nd harmonic inrush current)

• **HMI function**

- Selection of HMI: Standard LCD / large LCD / Separate large LCD
- Large LCD supports single line diagram indication and touch-type operation
- 24 configurable tri-state LEDs selectable red/green/yellow
- 7 Programmable function keys for user demand operation

• **Recording**

- Fault record
- Event record
- Disturbance record

• **Communication**

- IEC 60870-5-103 / IEC 61850
- IEC 62439 PRP/HSR

• **General functions**

- Eight settings groups
- Automatic supervision
- Metering and recording functions
- Time synchronization by external clock using IRIG-B or system network
- Password protection for settings and selection of local / remote control
- Checking internal circuit by forcible signal.
- Checking internal circuit using monitoring jacks.

APPLICATIONS

Control is performed remotely through the communication bus or locally from an HMI on the front panel showing the single line diagram for the bay or a menu. GBU200 can be applied in a standard configuration of one unit per bay, or alternatively one unit can be applied as a common device for several bays.

The GBU200 also provides protection features. Basic functions for feeder protection are equipped and configuration of addition/deletion of other protection functions is possible using professional version of the engineering tool (TOSHIBA IED Engineering & Monitoring Software).

Printed circuit boards for binary inputs/outputs, CT/PT modules, DCAI/DCAO modules and communication modules are configurably selectable upon users' requirement and applications, and configured by simple engineering work with the engineering tool software.

The GBU200 can operate as a control terminal within the substation automation system (SAS). The GBU200 can communicate with a server of the SAS by IEC 61850.

The GBU200 can communicate with conventional equipment such as legacy relays by hard-wiring and other protection relays or control units over IEC 61850-5-103 and the GBU200 can also function as a protocol converter to communicate with the SAS.

CONTROL

■ Switchgear Control

GBU200 provides functions for local control of switchgear from the HMI. Two-stepped operation (select-control) or direct control operation is applied for the control of circuit breakers, isolator switches and earthing switches.

Also, switchgear control commands from the station level can be performed through GBU200 within the application of a SAS.

■ Interlock check

The interlocking function blocks the operation of primary switching devices, for instance when a isolator switch is under load, in order to prevent material damage and/or accidental human injury.

Each switchgear control function has interlocking modules included for different switchyard arrangements, where each function handles interlocking for one bay. The interlocking function is distributed to each IED and is not dependent on any central function.

For station-level interlocking scheme, GBU200 communicates via the station bus or by hard-wiring. The interlocking conditions depend on the circuit configuration and apparatus position status at any given time. For easy and safe implementation of the interlocking function, standard software interlocking logic is provided in GBU200. The interlocking logic and conditions can be modified to satisfy the specific requirements by means of the graphical configuration tool.

■ Synchronism and voltage check

When the circuit breaker closing selection command is received, the integrated synchronism and voltage check function is performed to check feeder synchronization.

■ Split synchronism check

In case the circuit breaker closing command is received during an asynchronous network condition where frequencies are different between the line and bus sides, the split synchronism check mode automatically functions by detecting angle differences, instead of normal synchronism check mode.

■ Characteristics of synchronism check

The synchronism check scheme is shown in Figure 1.

The function includes a built-in voltage selection scheme for double bus and one- and a half breaker or ring busbar arrangements.

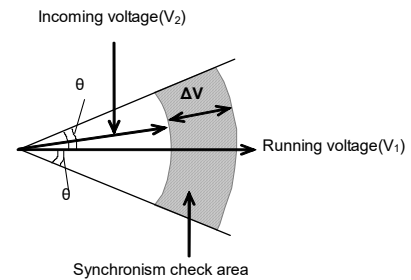

(a) Synchronism check zone

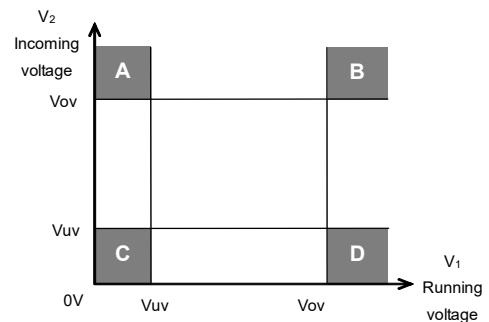

A, C, D: Voltage check
B: Synchronism check

(b) Voltage and synchronism check zone

Figure 1 - Synchronism check characteristic

MONITORING

■ Metering

The following power system data is measured continuously and can be displayed on the LCD on the relay fascia, and on a local or remotely connected PC.

- Measured analog voltages, currents, frequency, active- and reactive-power

The accuracy of analog measurement is $\pm 0.5\%$ for I, V, P, Q at rated input and $\pm 0.03\text{Hz}$ for frequency measurement.

■ Status Monitoring

The open or closed status of each switchgear device and failure information concerning power apparatus and control equipment are monitored by GBU200.

Both normally open and normally closed contacts are used to monitor the switchgear status. If an unusual status is detected, a switchgear abnormality alarm is generated.

■ DC analog inputs and outputs (option)

The DC analog inputs provide monitoring and supervision of measurement and process signals from measuring transducers. Many monitoring devices used in substation apparatus represent various parameters such as temperature, GIS gas pressure

and DC battery voltage as low current values.

These transducer inputs are also monitored on the local HMI or SAS.

■ Power Quality Measurement (option)

GBU200 provides power quality measurement features for the supervision of power system values. This function is available using an optional CT/PT card.

- Individual harmonic distortion from 2nd to 15th
- Total Harmonic Distortion (THD) and Total Demand Distortion (TDD) from 2nd to 15th
- Sag, Swell and Interruption

PROTECTION

■ Directional or non-directional phase overcurrent protection (OC)

Four steps of three-phase overcurrent functions have definite time or inverse time characteristics in which all IEC, ANSI and user-defined characteristics are available.

The function can be set to be directional or non-directional characteristics independently.

■ Directional or non-directional earth fault overcurrent protection (EF)

Four steps of earth fault overcurrent protection have definite time or inverse time characteristics in which all IEC, ANSI and optional user-defined characteristics are available.

The function can be set to be directional or non-directional characteristics independently.

■ Sensitive directional or non-directional earth fault overcurrent protection (SEF) (Option)

This function provides two steps of earth fault overcurrent protection with more sensitive settings for use in applications where the fault current magnitude may be very low.

The sensitive earth fault quantity is measured directly, using a dedicated core balance earth fault CT.

The function can be set to be directional or non-directional independently.

■ Thermal overload protection (THM)

The thermal overload feature provides protection for cables and other plant against the effects of prolonged operation under excess load conditions. A thermal replica algorithm is applied to create a model for the thermal characteristics of the protected plant. Tripping times depend not only on the level of overload current, but also on the level of prior load current, the thermal replica providing 'memory' of previous conditions.

■ Under and over voltage protection (UV/OV)

Both undervoltage and overvoltage protection schemes are provided. Each scheme can be programmed with definite or inverse time delay.

■ Frequency protection (FRQ)

6 independent frequency stages are provided. Each is programmable for either under-frequency or over-frequency operation, and each has an associated DTL timer. The underfrequency function can be applied to implement load-shedding schemes.

■ Negative sequence overcurrent protection (OCN)

Four steps of negative sequence overcurrent protection have definite time or inverse time characteristics.

The function can be set to be directional or non-directional characteristics independently.

■ **Voltage Controlled Protection**

Voltage controlled or voltage restraint inverse overcurrent protection is equipped so that the relay can issue a trip signal in response to certain fault types on the lower voltage side of a transformer when the fault current may be lower than the nominal value. The user can select either the voltage controlled OCI or the voltage restraint OCI function in addition to the normal OCI function. When voltage controlled OCI is used, only when an input voltage is lower than a setting, the OCI element functions. When voltage restraint OCI is used, the sensitivity of OCI is proportionally adjusted by the voltage input value between 20 and 100% of the voltage setting.

■ **Broken Conductor Protection (BCD)**

The unbalance condition caused by an open circuited conductor is detected by the broken conductor protection. An unbalance threshold with programmable definite time delay is provided.

■ **Circuit Breaker Fail Protection (CBF)**

Two stage CBF protection provides outputs for re-tripping of the local circuit breaker and/or back-tripping to upstream circuit breakers. The CBF functions can also be initiated by external protections via a binary input if required.

■ **Cold Load Protection**

The cold load function modifies the overcurrent protection settings by changing the setting group for a period after energizing the system. This feature is used to prevent unwanted protection operation when closing on to the type of load which takes a high level of current for a period after energization. This is achieved by a 'Cold Load Settings Group' in which the user can program alternative settings. Normally the user will choose higher current settings and/or longer time delays and/or disable elements altogether within this group.

■ **Inrush Current Detection (ICD)**

Inrush current detector ICD detects second harmonic inrush current during transformer energization and can block OC, EF, SEF, OCN and BCD elements.

■ **Auto Reclose (ARC)**

Four independent sequences are provided. Each protection trip such as phase fault, earth fault or an external trip signal is programmable for instantaneous or delayed operation and each ARC shot has a programmable dead time. Either simple ARC shot or normal ARC shot with synchronization check for three-phase autoreclose is settable for the first sequence.

HMI FUNCTION

■ **Front Panel**

GBU200 provides the following front panel options.

- Standard LCD
- Large LCD (optional separate LCD type is also available)



Figure 2 - HMI Panel (large LCD type)

The standard LCD panel incorporates the user interfaces listed below. Setting the relay and viewing stored data are possible using the Liquid Crystal Display (LCD) and operation keys.

- 21 character, 8 line LCD with back light
- Support of English language

The large LCD panels incorporate a touch type screen for control and navigation purposes.

- 40 character, 40 line LCD with back light

The local human machine interface includes an LCD which can display the single line diagram for the bay.

The local human machine interface is simple and easy to understand with the following facilities and indications.

- Status indication LEDs (IN SERVICE, ERROR and 24 configurable LEDs)
- 7 Function keys for control, monitoring, setting group change and screen jump functions of which operation is configurable by the user
- Test terminals which can monitor three different signals from the front panel without connection to the rear terminals.
- USB port

■ Local PC connection

The user can communicate with GBU200 from a local PC via the USB port on the front panel. Using GR-200 series engineering tool software (called GR-TIEMS),

the user can view, change settings and monitor real-time measurements.

RECORDING

■ Event Record

Continuous event-logging is useful for monitoring of the system from an overview perspective and is a complement to specific disturbance recorder functions. Up to 1,024 time-tagged events are stored with 1ms resolution.

■ Fault records

Information about the pre-fault and fault values for currents and voltages are recorded and displayed for trip event confirmation. The most recent 8 time-tagged faults with 1ms resolution are stored. Fault record items are as follows.

- Date and time
- Faulted phase
- Tripping phase
- Operating mode
- Pre-fault and post-fault current and voltage data (phase, phase to phase, symmetrical components)
- Autoreclose operation
- Fault location

Fault location is initiated by relay tripping signals.

It can also be started on receipt of a start signal from external relays.

Fault location is indicated in km or mile and % for the whole length of the protected line. The fault location is highly accurate for parallel lines due to the implementation of zero-sequence mutual impedance compensation.

The result of the fault location is stored as fault record data.

■ Disturbance records

The Disturbance Recorder function supplies fast, complete and reliable information for disturbances in the power system. It facilitates understanding of system behavior and performance of related primary and secondary equipment during and after a disturbance.

The Disturbance Recorder acquires sampled data from all selected analogue inputs and binary signals. The data is stored in COMTRADE format.

COMMUNICATION

■ Station bus

Ethernet port(s) for the substation communication standards IEC 61850 is provided for the station bus. GBU200 also support Ethernet redundancy scheme protocols defined in the IEC 62439-3 standard: PRP/HSR.

■ Serial communication

Serial port (RS485 and fiber optic) for communicating with legacy equipment or protection relays over IEC 60870-5-103 protocol is provided. The GBU200 can function as a protocol converter to connect SAS.

GENERAL FUNCTION

■ Self supervision

Automatic self-supervision of internal circuits and software is provided. In the event of a failure being detected, the ALARM LED on the front panel is illuminated, the 'UNIT FAILURE' binary output operates, and the date and time of the failure is recorded in the event record.

■ Time synchronization

Current time can be provided with time synchronization via the station bus by SNTP (Simple Network Time Protocol) with the IEC 61850 protocol. IRIG-B port is also available as an option.

■ Setting groups

8 settings groups are provided, allowing the user to set

one group for normal conditions, while the other groups may be set to cover alternative operating conditions.

■ Password protection

Password protection is available for the execution of setting changes, executing control, clearing records and switching between local/remote control.

TOOLS & ACCESSORY

The PC interface GR-TIEMS allows users to access GBU200 and other Toshiba GR-200 series IEDs from a local personal computer (PC) to view on-line or stored data, to change settings, to edit the LCD screen, to configure sequential logics and for other purposes.

■ REMOTE SETTING AND MONITORING

The engineering tool supports functions to change settings and to view and analyze fault and disturbance records stored in GBU200. Waveform data in the disturbance records can be displayed, edited, measured and analyzed in detail. An advanced version of the engineering tool can provide additional and powerful analysis tools and setting calculation support functions.

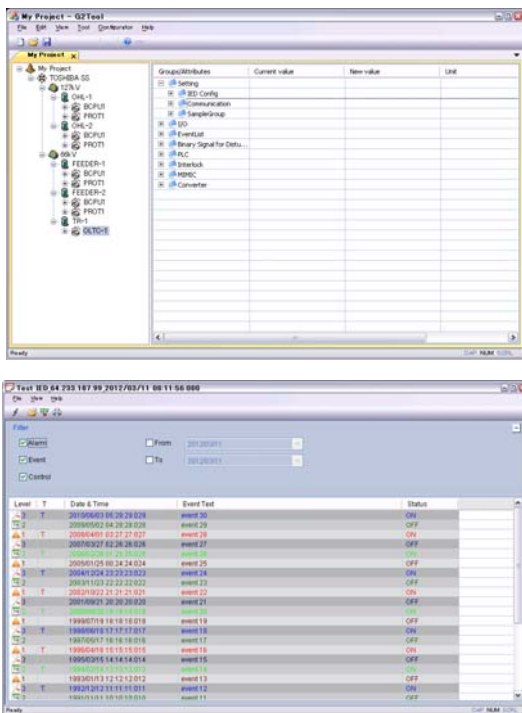

Figure 3 PC Display of GR-TIEMS

■ Simulation and test

GBU200 provides simulation and test functions to check control functions without modification to wiring provided by a dummy circuit breaker (virtual equipment), and the capability to test communication signals by forced signal status change.

The simulation and test can work in the Test mode only.

■ LCD CONFIGURATION

The user can configure and customize the MIMIC data displayed on the LCD of GBU200 using GR-TIEMS software.

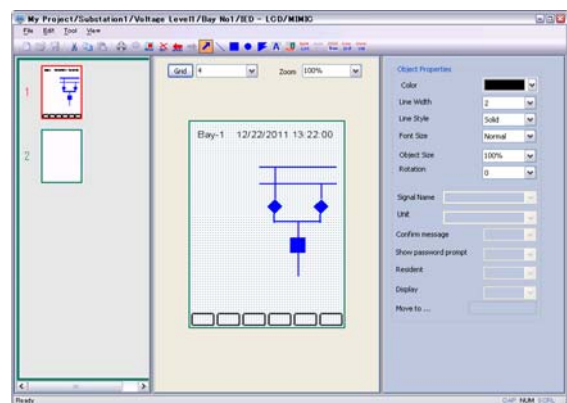

Figure 4 PC Display of MIMIC configuration

■ PROGRAMMABLE LOGIC EDITOR

The programmable logic capability allows the user to configure flexible logic for customized application and operation. Configurable binary inputs, binary outputs and LEDs are also programmed by the programmable logic editor which is compiled with IEC 61131-3.

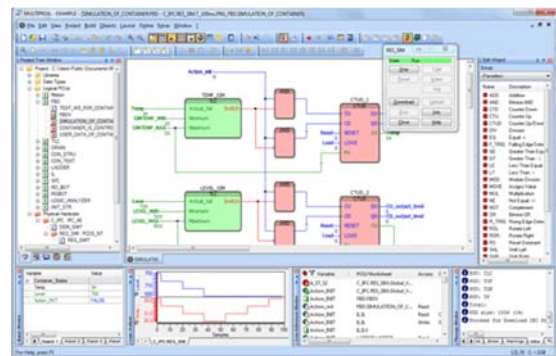

Figure 5 PC display of PLC editor

External IO Unit - GIO200

GIO200 external IO unit is provide for additional inputs and outputs modules to GBU200. Maximum 1 unit of GIO200 can be connected with

GBU200, and functions as one unit with GBU200. Same IO modules with GBU200 can be mounted on GIO200.

TECHNICAL DATA

HARDWARE	
Analog Inputs	
Rated current I_n	1A / 5A (selectable by user)
Rated voltage V_n	100V to 120V
Rated Frequency	50Hz / 60Hz (selectable by user)
Overload Rating	
Current inputs	4 times rated current continuous 5 times rated current for 3 mins 6 times rated current for 2 mins 30 times rated current for 10 sec 100 times rated current for 1 second 250 times rated current for one power cycle (20 or 16.6ms)
Voltage inputs	2 times rated voltage continuous 2.5 times rated voltage for 1 second
Burden	
Phase current inputs	$\leq 0.1VA$ at $I_n = 1A$, $\leq 0.2VA$ at $I_n = 5A$
Earth current inputs	$\leq 0.3VA$ at $I_n = 1A$, $\leq 0.4VA$ at $I_n = 5A$
Sensitive earth fault inputs	$\leq 0.3VA$ at $I_n = 1A$, $\leq 0.4VA$ at $I_n = 5A$
Voltage inputs	$\leq 0.1VA$ at V_n
Power Supply	
Rated auxiliary voltage	24/48/60Vdc (Operative range: 19.2 – 72Vdc), 48/125Vdc (Operative range: 38.4 – 150Vdc), 110/250Vdc or 100/220Vac (Operative range: 88 – 300Vdc or 80 – 230Vac) <Notes> 1) Binary inputs are intended for use with DC power source only. 2) The power supply supervision function is intended for use with DC power source only. It should be disabled when AC power supply is applied in order to prevent spurious alarms.
Superimposed AC ripple on DC supply	$\leq 15\%$
Power supply interruption withstand period (IEC 60255-11)	24/48/60Vdc rating: 20ms 48/125Vdc rating: 35ms 110/125Vdc rating: 50ms
Power consumption	$\leq 15W$ (quiescent) $\leq 25W$ (maximum)
Binary Inputs	
Input circuit DC voltage	24/48/60Vdc (Operating range: 19.2 – 72Vdc), 48/125Vdc (Operative range: 38.4 – 150Vdc), 110/125/220/250Vdc (Operating range: 88 – 300Vdc) Note: Pick-up setting is available in BI2 and BIO4 (Setting range: 18V to 222V)
Capacitive discharge immunity	10 μ F charged to maximum supply voltage and discharged into the input terminals, according to ENA TS 48-4 with an external resistor
Maximum permitted voltage	72Vdc for 24/48/60Vdc rating, 300Vdc for 110/250Vdc rating
Power consumption	$\leq 0.5W$ per input at 220Vdc
Binary Outputs	
Fast operating contacts	
Make and carry	5A continuously 30A, 290Vdc for 0.2s (L/R=5ms)

Break Operating time	0.15A, 290Vdc (L/R=40ms) Typically 3 ms
Semi-fast operating contacts Make and carry Break Operating time	8A continuously 30A, 240Vdc for 1s (L/R=5ms) 0.1A at 250Vdc (L/R=40ms) 0.2A at 110Vdc (L/R=40ms) Typically 6 ms
Auxiliary contacts Make and carry Break Operating time	8A continuously 30A, 240Vdc for 1s (L/R=5ms) 0.1A at 250Vdc (L/R=40ms) 0.2A at 110Vdc (L/R=40ms) Typically 8 ms
Hybrid contacts (10 A breaking) Make and carry Break Operating time	8A continuously 10A, 220Vdc for 0.5s (L/R=5ms) 10A, 220Vdc (L/R=20ms) 10A, 110Vdc (L/R=40ms) 1 ms
Durability	≥ 10,000 operations (loaded contact) ≥ 100,000 operations (unloaded contact)
DC-AI (analog inputs)	
Measurement range Accuracy Maximum permitted continuous current Input resistance	DC 0±1mA, 0±20mA, 4–20mA, 0–10mA, 0–20mA, ±10mA DC -1 – 0 – +1V, -5 – 0 – +5V, -10 – 0 – +10V ±0.5% of full scale 2 times for maximum measurement range Depend on current and voltage range: ±1mA: 4.7k ohm, ±20mA: 235 ohm ±10V: 38k ohm, ±1V: 580k ohm
DC-AO (analog outputs)	
Measurement range Accuracy	DC 0 – ±20mA DC 0 – ±10V ±1% of full scale
Measuring input capability	
Full scale Standard current input Sensitive current input Voltage input Sampling rate Frequency response	≥ 60A (1A rating) or 300A (5A rating) ≥ 3A (1A rating) or 15 A (5A rating) ≥ 200V 48 samples / cycle < 5% deviation over range 16.7Hz to 600Hz
Mechanical Design	
Installation Weight Case color	Flush mounting Approx. 10kg (1/3 size), 12kg (1/2 size), 15kg (3/4 size), 25kg (1/1 size) 2.5Y7.5/1 (approximation to Munsell value)
LED	
Number Color	26 (Fixed for “In service” and “ERROR”) Red / Yellow / Green (configurable) except In service (green) and Error (red)
Function keys	
Number	7
Local Interface	

USB Maximum cable length	Type B 2m (max.)
System Interface (rear port)	
100BASE-TX/1000BASE-T Cable type Connector type	For IEC 61850-8-1 and GR-TIEMS CAT5e STP cable - enhanced category 5 with Shielded Twisted Pair cable RJ-45
100BASE-FX Cable type Connector type Wave length	For IEC 61850-8-1 Multimode fibre, 50/125 or 62.5/125mm SC duplex type 1300nm
1000BASE-LX Cable type Connector type Wave length	For IEC 61850-8-1 Single-mode fibre LC duplex connector 1310nm
RS485 Cable type Connector type	For IEC 60870-5-103 Shielded twisted pair cable Push-in spring terminal (PCB connector)
Fiber optical (for serial communication) Cable type Connector type Wave length	For IEC 60870-5-103 Multimode fibre, 50/120 μ m or 62.5/125 μ m ST type 820nm
IRIG-B (for time synchronization) Cable type Connector type	Shielded twisted pair cable Push-in spring terminal (PCB connector)
Terminal Block	
CT/VT input Binary input, Binary output	M3.5 Ring terminal Compression plug type terminal

FUNCTIONAL DATA

CONTROL

Synchronism Check Function	
Synchronism check angle:	0 – 75° in 1° steps
Frequency difference check:	0.01– 2.00Hz in 0.01Hz steps
Voltage difference check:	1.0 – 150.0V in 0.1V steps
Voltage dead check:	5 – 50V in 1V steps
Voltage live check:	10 – 100V in 1V steps
Metering Function	
Current	Accuracy ± 0.5% (at rating)
Voltage	Accuracy ± 0.5% (at rating)
Power (P, Q)	Accuracy ± 0.5% (at rating)
Energy (Wh, varh)	Accuracy ± 1.0% (at rating)
Frequency	Accuracy ± 0.03Hz
Power Quality Measurement	
Current harmonic distortion (up to 15 th)	± 1.0% I _n , if I _m < 10% I _n ; ± 10 % I _m , if I _m >10% I _n
Voltage harmonic distortion (up to 15 th)	± 0.3% U _n , if U _m <3 % I _n ; ± 10 % U _m , if U _m >3% U _n
GPS Time Synchronisation	
Protocol	SNTP

PROTECTION

Directional Phase Overcurrent Protection	
IDMTL Overcurrent threshold:	0.02 – 5.00A in 0.01A steps (1A rating) 0.10 – 25.00A in 0.01A steps (5A rating)
DTL Overcurrent threshold:	0.02 – 50.00A in 0.01A steps (1A rating) 0.10 – 250.00A in 0.01A steps (5A rating)
DO/PU ratio:	10 – 100% in 1% steps
Delay type:	DT, IEC NI, IEC VI, IEC EI, IEC LTI, IEEE MI, IEEE VI, IEEE EI, US CO2 STI, US CO8 I
IDMTL Time Multiplier Setting TMS:	0.010 – 50.000 in 0.001 steps
DTL delay:	0.00 – 300.00s in 0.01s steps
Reset Type:	Definite Time or Dependent Time.
Reset Definite Delay:	0.00 – 300.00s in 0.01s steps
Reset Time Multiplier Setting RTMS:	0.010 – 50.00 in 0.001 steps
Directional Characteristic Angle:	0° to 180° in 1° steps
Directional Earth Fault Protection	
IDMTL Overcurrent threshold:	0.02 – 5.00A in 0.01A steps (1A rating) 0.10 – 25.00A in 0.01A steps (5A rating)
DTL Overcurrent threshold:	0.02 – 50.00A in 0.01A steps (1A rating) 0.10 – 250.00A in 0.01A steps (5A rating)
DO/PU ratio:	10 – 100% in 1% steps
Delay type:	DT, IEC NI, IEC VI, IEC EI, IEC LTI, IEEE MI, IEEE VI, IEEE EI, US CO2 STI, US CO8 I
IDMTL Time Multiplier Setting TMS:	0.010 – 50.000 in 0.001 steps
DTL delay:	0.00 – 300.00s in 0.01s steps
Reset Type:	Definite Time or Dependent Time.
Reset Definite Delay:	0.00 – 300.00s in 0.01s steps
Reset Time Multiplier Setting RTMS:	0.010 – 50.000 in 0.001 steps
Directional Characteristic Angle:	0° to 180° in 1° steps

Directional Characteristic Polarising Voltage threshold:	0.5 – 100.0V in 0.1V steps
Directional Sensitive Earth Fault Protection	
Overcurrent threshold:	0.002 – 0.200A in 0.001A steps (1A rating) 0.010 – 1.000A in 0.001A steps (5A rating)
Delay Type:	DT, IEC NI, IEC VI, IEC EI, IEC LTI, IEEE MI, IEEE VI, IEEE EI, US CO2 STI, US CO8 I
IDMTL Time Multiplier Setting TMS:	0.010 – 50.000 in 0.001 steps
DTL delay:	0.00 – 300.00s in 0.01s steps
Reset Type:	Definite Time or Dependent Time
Reset Definite Delay:	0.00 – 300.00s in 0.01s steps
Reset Time Multiplier Setting RTMS:	0.010 – 50.000 in 0.001 steps
Directional Characteristic angle:	0° to 180° in 1° steps
Directional Characteristic Boundary of operation:	±87.5°
Directional Characteristic Voltage threshold:	0.5 – 100.0V in 0.1V steps
Residual power threshold:	0.00 – 20.00W in 0.05W (1A rating) 0.00 – 100.00W in 0.25W (5A rating)
Overvoltage Protection	
Overvoltage (OV) thresholds:	1.0 – 220.0V in 0.1V steps
OV delay type:	DTL, IDMTL
OV IDMTL Time Multiplier Setting TMS:	0.010 – 100.000 in 0.001 steps
OV DTL delay:	0.00 – 300.00s in 0.01s steps
DO/PU ratio:	10 – 100% in 1% steps
1 st OV Reset Delay:	0.0 – 300.0s in 0.1s steps
Undervoltage Protection	
Undervoltage (UV) thresholds:	5.0 – 130.0V in 0.1V steps
UV delay type:	DTL, IDMTL
UV IDMTL Time Multiplier Setting TMS:	0.010 – 100.000 in 0.001 steps
UV DTL delay:	0.00 – 300.00s in 0.01s steps
UV Reset Delay:	0.0 – 300.0s in 0.1s steps
Under/Over Frequency Protection	
Under/Over frequency threshold:	-10.00 – +10.00Hz in 0.01Hz steps
DTL delay:	0.00 – 300.00s in 0.01s steps
Undervoltage block:	40.0 – 100.0V in 0.1V steps
Voltage Restraint Protection (51V)	
Voltage threshold	10.0 to 120.0V in 0.1V steps
Sensitivity range	20 to 100% of voltage threshold
Thermal Overload Protection	
$I_0 = k \cdot I_{FLC}$ (Thermal setting):	0.40 – 2.00A in 0.01A steps (1A rating) 2.00 – 10.00A in 0.01A steps (5A rating)
Time constant (τ):	0.5 - 500.0 mins in 0.1min steps
Thermal alarm:	50 - 100% in 1% steps
Inrush Current Detector	
Second harmonic ratio setting (I_{2f}/I_{1f}):	10 – 50% in 1%
Overcurrent thresholds:	1.00 – 5.00A in 0.01A steps (1A rating) 5.00 – 25.00A in 0.01A steps (5A rating)
Accuracy	
IDMTL Overcurrent Pick-up:	Setting value \pm 2%
All Other Overcurrent Pick-ups:	Setting value \pm 5%
Overcurrent PU/DO ratio:	\geq 95%

Undercurrent Pick-up:	Setting value \pm 2%
Undercurrent PU/DO ratio:	\leq 105%
IDMTL Overvoltage Pick-up:	Setting value \pm 2%
All Other Overvoltage Pick-ups:	Setting value \pm 5%
Inverse Time Delays:	\pm 5% or 30ms (1.5 to 30 times setting)
Definite Time Delays:	\pm 1% (for more than 50ms setting) or 10ms
Transient Overreach for instant. elements:	$<$ -5% for X/R = 100.

ENVIRONMENTAL PERFORMANCE

Atmospheric Environment		
Temperature	IEC 60068-2-1/2 IEC 60068-2-14	Operating range: -10°C to +55°C. Storage / Transit: -25°C to +70°C. Cyclic temperature test as per IEC 60068-2-14
Humidity	IEC 60068-2-30 IEC 60068-2-78	56 days at 40°C and 93% relative humidity. Cyclic temperature with humidity test as per IEC 60068-2-30
Enclosure Protection	IEC 60529	IP52 - Dust and Dripping Water Proof IP20 for rear panel
Mechanical Environment		
Vibration	IEC 60255-21-1	Response - Class 1 Endurance - Class 1
Shock and Bump	IEC 60255-21-2	Shock Response Class 1 Shock Withstand Class 1 Bump Class 1
Seismic	IEC 60255-21-3	Class 1
Electrical Environment		
Dielectric Withstand	IEC 60255-5	2kVrms for 1 minute between all terminals and earth. 2kVrms for 1 minute between independent circuits. 1kVrms for 1 minute across normally open contacts.
High Voltage Impulse	IEC 60255-5 IEEE C37.90	Three positive and three negative impulses of 5kV(peak), 1.2/50 μ s, 0.5J between all terminals and between all terminals and earth.
Voltage Dips, Interruptions, Variations and Ripple on DC supply	IEC 60255-11, IEC 61000-4-29, IEC 61000-4-17 IEC 60255-26 Ed 3	1. Voltage dips: 0 % residual voltage for 20 ms 40 % residual voltage for 200 ms 70 % residual voltage for 500 ms 2. Voltage interruptions: 0 % residual voltage for 5 s 3. Ripple: 15 % of rated d.c. value, 100 / 120 Hz 4. Gradual shut-down / start-up: 60 s shut-down ramp, 5 min power off, 60s start-up ramp 5. Reversal of d.c. power supply polarity: 1 min
Capacitive Discharge	ENA TS 48-4	10 μ F charged to maximum supply voltage and discharged into the input terminals with an external resistance

Electromagnetic Environment		
High Frequency Disturbance / Damped Oscillatory Wave	IEC 60255-22-1 Class 3, IEC 61000-4-18 IEC 60255-26 Ed 3	1 MHz burst in common / differential modes Auxiliary supply and I/O ports: 2.5 kV / 1 kV Communications ports: 1 kV / 0 kV
Electrostatic Discharge	IEC 60255-22-2 Class 4, IEC 61000-4-2 IEEE C37.90.3-2001 IEC 60255-26 Ed 3	Contact: 2, 4, 6, 8kV Air: 2, 4, 8, 15kV
Radiated RF Electromagnetic Disturbance	IEC 60255-22-3, IEC 61000-4-3 Level 3 IEC 60255-26 Ed 3	Sweep test ranges: 80 MHz to 1 GHz and 1.4 GHz to 2.7 GHz. Spot tests at 80, 160, 380, 450, 900, 1850 and 2150 MHz. Field strength: 10 V/m
Radiated RF Electromagnetic Disturbance	IEEE C37.90.2-1995	Field strength 35V/m for frequency sweep of 25MHz to 1GHz.
Fast Transient Disturbance	IEC 60255-22-4 IEC 61000-4-4 IEC 60255-26 Ed 3	5 kHz, 5/50ns disturbance Auxiliary supply and input / output ports: 4 kV Communications ports: 2 kV
Surge Immunity	IEC 60255-22-5 IEC 61000-4-5 IEC 60255-26 Ed 3	1.2/50µs surge in common/differential modes: Auxiliary supply and input / output ports: 4, 2, 1, 0.5 kV / 1, 0.5 kV Communications ports: up to 1, 0.5 kV / 0 kV
Surge Withstand	IEEE C37.90.1-2002	3kV, 1MHz damped oscillatory wave 4kV, 5/50ns fast transient
Conducted RF Electromagnetic Disturbance	IEC 60255-22-6 IEC 61000-4-6 IEC 60255-26 Ed 3	Sweep test range: 150 kHz to 80MHz Spot tests at 27 and 68 MHz. Voltage level: 10 V r.m.s
Power Frequency Disturbance	IEC 60255-22-7 IEC 61000-4-16 IEC 60255-26 Ed 3	50/60 Hz disturbance for 10 s in common / differential modes Binary input ports: 300 V / 150 V
Power Frequency Magnetic Field	IEC 61000-4-8 Class 4 IEC 60255-26 Ed 3	Field applied at 50/60Hz with strengths of: 30A/m continuously, 300A/m for 1 second.
Conducted and Radiated Emissions	IEC 60255-25 EN 55022 Class A, EN 61000-6-4 IEC 60255-26 Ed 3	Conducted emissions: 0.15 to 0.50MHz: <79dB (peak) or <66dB (mean) 0.50 to 30MHz: <73dB (peak) or <60dB (mean) Radiated emissions 30 to 230 MHz: < 40 dB(uV/m) 230 to 1000 MHz: < 47 dB(uV/m) Measured at a distance of 10 m

Performance and Functional Standards		
Category	Standards	
General		
Common requirements	IEC 60255-1	
Data Exchange	IEC 60255-24 / IEEE C37.111 (COMTRADE) IEEE C37-239 (COMFEDE)	
Product Safety	IEC 60255-27	
European Commission Directives		
	2014/30/EU	Compliance with the European Commission Electromagnetic Compatibility Directive is demonstrated according to EN 60255-26: 2013.
	2014/35/EU	Compliance with the European Commission Low Voltage Directive for electrical safety is demonstrated according EN 60255-27:2014.

ORDERING SHEET

[Hardware selection] No VCT Module Model for Software '31' and '32'

										Positions																				
										-	7	8	-	9	A	B	-	C	D	-	E	F	-	G	H	-	J	K	L	
Configurations										G	B	U	2	0	0	-	0	-	-	-	-	-	-	-	-	-	-	0	0	0
Application of power system																														
BCU without Power Quantity Metering																														
No VCT module										0																				
DC rated voltage																														
110-250 Vdc or 100-220Vac (See (*1))										1																				
24/48/60 Vdc										3																				
System Frequency																														
N/A										0																				
AC rated current																														
N/A										0																				
Outline																														
Standard LCD, 1/2 x 19" rack for flush mounting										2																				
Large LCD, 1/2 x 19" rack for flush mounting										6																				
Standard LCD, 1/2 x 19" rack for rack mounting (See (*2))										F																				
Large LCD, 1/2 x 19" rack for rack mounting (See (*2))										J																				
Terminal block for BIO and PWS																														
Compression plug type terminal										0																				
BI/BO module																														
Choice from BI/BO table										1 x BIO module 1 *																				
										2 x BIO modules 2 *																				
										3 x BIO modules 3 *																				
Terminal block for BIO and PWS																														
Ring type terminal										1																				
BI/BO module																														
Choice from BI/BO table										1 x BIO modules 1 *																				
										2 x BIO modules 2 *																				
Outline																														
Standard LCD, 3/4 x 19" rack for flush mounting										3																				
Large LCD, 3/4 x 19" rack for flush mounting										7																				
Standard LCD, 3/4 x 19" rack for rack mounting (See (*2))										G																				
Large LCD, 3/4 x 19" rack for rack mounting (See (*2))										K																				
Terminal block for BIO and PWS																														
Compression plug type terminal										0																				
BI/BO module																														
Choice from BI/BO table										1 x BIO module 1 *																				
										2 x BIO modules 2 *																				
										3 x BIO modules 3 *																				
										4 x BIO modules 4 *																				
										5 x BIO modules 5 *																				
										6 x BIO modules 6 *																				
Terminal block for BIO and PWS																														
Ring type terminal										1																				
BI/BO module																														
Choice from BI/BO table										1 x BIO module 1 *																				
										2 x BIO modules 2 *																				
										3 x BIO modules 3 *																				
										4 x BIO modules 4 *																				

[Hardware selection] No VCT Module Model for Software '31' and '32'

Configurations	Positions																									
	G	B	U	2	0	0	-	7	8	-	9	A	B	-	C	D	-	E	F	-	G	H	-	J	K	L
Outline							-	0		-				-	0	0	-			-			-	0	0	0
Standard LCD, 1/1 x 19" rack for flush/rack mounting																										
Large LCD, 1/1 x 19" rack for flush/rack mounting																										
Terminal block for BIO and PWS																										
Compression plug type terminal																										0
BI/BO module																										
Choice from BI/BO table																										
1×BIO module												1	*													
2×BIO modules												2	*													
3×BIO modules												3	*													
4×BIO modules												4	*													
5×BIO modules												5	*													
6×BIO modules												6	*													
7×BIO modules												7	*													
8×BIO modules												8	*													
Terminal block for BIO and PWS																										
Ring type terminal																										1
BI/BO module																										
Choice from BI/BO table																										
1×BIO module												1	*													
2×BIO modules												2	*													
3×BIO modules												3	*													
4×BIO modules												4	*													
5×BIO modules												5	*													
6×BIO modules												6	*													
7×BIO modules												7	*													
Number of Serial and/or Ethernet Communication and/or Time Synch Port(s) and/or usage of extension IO unit (GIO200)																										
Refer to Communication port Table (See(*3))																										
Function Block (linked with software selection)																										
See function table of software selection																										

[Software selection]

Configurations	Positions																	
	G	B	U	2	0	0	-	7	S	G	N	-	E	F	U	-	9	V
(BCU without Power Quantity Metering)	G	B	U	2	0	0	-	0	0	3	1 or 2	-				-		E

- (*1) Binary inputs are intended for use with DC power source only.
The power supply supervision function is intended for use with DC power source only. It should be disabled when AC power supply is applied in order to prevent spurious alarms.
- (*2) For 19" rack panel mounting, accessories of joint kits are available. (See Figure 10)
EP-204 for single 1/2 x 19" size rack, EP-205 for two 1/2 x 19" size racks and EP-206 for single 3/4 x 19" size rack.
- (*3) For PRP/HSR/RSTP protocol with IEC 61850, choose "L", "N", "P" or "R" code at position E. For hot/standby configuration or single port configuration with IEC 61850, choose other codes at position E.

Please contact with our sales staffs when you require user configurable models that are not indicated in the ordering sheet above.

[Hardware selection] Single VCT Module Model for Software '31', '32', '34' and '35'

										Positions																								
										-	7	8	-	9	A	B	-	C	D	-	E	F	-	G	H	-	J	K	L					
Configurations										G	B	U	2	0	0	-	-	-	0	0	-	-	-	-	-	-	-	-	-	0				
Application of power system																																		
BCU with Protections (BCPU)																																		
CT/VT module with sensitive CT input (VCT51B) – CT x 4, CTsef x 1, VT x 6 (for BCPU)										1																								
BCU without Protections (BCU)																																		
CT/VT module (VCT52B) – CT x 4, VT x 5 (for BCU)										2																								
CT/VT module for bus section or bus coupler bays (VCT53B) – CT x 4, VT x 7 (for BCU)										3																								
DC rated voltage																																		
110-250 Vdc or 100-220Vac (See (*1))										1																								
24/48/60 Vdc										3																								
System Frequency																																		
50Hz																													1					
60Hz																														2				
AC rated current																																		
1A																													1					
5A																														2				
Outline																																		
Standard LCD, 1/2 x 19" rack for flush mounting																														2				
Large LCD, 1/2 x 19" rack for flush mounting																														6				
Standard LCD, 1/2 x 19" rack for rack mounting (See (*2))																														F				
Large LCD, 1/2 x 19" rack for rack mounting (See (*2))																															J			
Terminal block for BIO and PWS																																		
Compression plug type terminal																														0				
BI/BO module																																		
Choice from BI/BO table																																		
1xBIO module																														1 *				
2xBIO modules																														2 *				
3xBIO modules																															3 *			
Terminal block for BIO and PWS																																		
Ring type terminal																															1			
BI/BO module																																		
Choice from BI/BO table																																		
1xBIO modules																															1 *			
2xBIO modules																															2 *			
3xBIO modules																																3 *		
4xBIO modules																																4 *		
5xBIO modules																																5 *		
6xBIO modules																																6 *		
Outline																																		
Standard LCD, 3/4 x 19" rack for flush mounting																															3			
Large LCD, 3/4 x 19" rack for flush mounting																															7			
Standard LCD, 3/4 x 19" rack for rack mounting (See (*2))																																G		
Large LCD, 3/4 x 19" rack for rack mounting (See (*2))																																	K	
Terminal block for BIO and PWS																																		
Compression plug type terminal																																0		
BI/BO module																																		
Choice from BI/BO table																																		
1xBIO module																																1 *		
2xBIO modules																																2 *		
3xBIO modules																																	3 *	
4xBIO modules																																	4 *	
5xBIO modules																																	5 *	
6xBIO modules																																	6 *	
Terminal block for BIO and PWS																																		
Ring type terminal																																	1	
BI/BO module																																		
Choice from BI/BO table																																		
1xBIO module																																	1 *	
2xBIO modules																																	2 *	
3xBIO modules																																		3 *
4xBIO modules																																		4 *

[Hardware selection] Single VCT Module Model for Software '31', '32', '34' and '35'

							Positions																					
							-	7	8	-	9	A	B	-	C	D	-	E	F	-	G	H	-	J	K	L		
Configurations							G	B	U	2	0	0	-						0	0	-							0
Outline																												
Standard LCD, 1/1 x 19" rack for flush/rack mounting														4														
Large LCD, 1/1 x 19" rack for flush/rack mounting														8														
Terminal block for BIO and PWS																												
Compression plug type terminal																										0		
BI/BO module																												
Choice from BI/BO table														1	*													
														2	*													
														3	*													
														4	*													
														5	*													
														6	*													
														7	*													
														8	*													
Terminal block for BIO and PWS																												
Ring type terminal																										1		
BI/BO module																												
Choice from BI/BO table														1	*													
														2	*													
														3	*													
														4	*													
														5	*													
														6	*													
														7	*													
Number of Serial and/or Ethernet Communication and/or Time Synch Port(s) and/or usage of extension IO unit (GIO200)																												
Refer to Communication port Table (See(*3))																												
Function Block (linked with software selection)																												
See function table of software selection																												

[Software selection]

							Positions																						
							7	S	G	N	E	F	U	9	V														
Configurations (BCPU: BCU with Protection)							G	B	U	2	0	0	-	1	0	3	1, 2, 4 or 5	-										E	
Configurations (BCU: BCU without Protection)							G	B	U	2	0	0	-	2 or 3	0	3	1, 2, 4 or 5	-											E

- (*1) Binary inputs are intended for use with DC power source only.
The power supply supervision function is intended for use with DC power source only. It should be disabled when AC power supply is applied in order to prevent spurious alarms.
- (*2) For 19" rack panel mounting, accessories of joint kits are available. (See Figure 10)
EP-204 for single 1/2 x 19" size rack, EP-205 for two 1/2 x 19" size racks and EP-206 for single 3/4 x 19" size rack.
- (*3) For PRP/HSR/RSTP protocol with IEC 61850, choose "L", "N", "P" or "R" code at position E. For hot/standby configuration or single port configuration with IEC 61850, choose other codes at position E.

Please contact with our sales staffs when you require user configurable models that are not indicated in the ordering sheet above.

[Hardware selection] Double VCT Module Model for Software '31', '32', '34' and '35'

Configurations	Positions																									
	G	B	U	2	0	0	-	7	8	-	9	A	B	-	C	D	-	E	F	-	G	H	-	J	K	L
Application of power system															0	0										0
BCU with Protections (BCPU)																										
CT/VT module with sensitive CT input (VCT51B) – CT x 4, CTsef x 1, VT x 6 (for BCPU) with power quality monitoring input (VCT54B)								4																		
BCU without Protections (BCU)																										
CT/VT module (VCT52B) – CT x 4, VT x 5 (for BCU) with power quality monitoring input (VCT55B)								5																		
CT/VT module for bus section or bus coupler bays (VCT53B) – CT x 4, VT x 7 (for BCU) with power quality monitoring input (VCT56B)								6																		
DC rated voltage																										
110-250 Vdc or 100-220Vac (See (*1))									1																	
24/48/60 Vdc									3																	
System Frequency																										
50Hz																									1	
60Hz																									2	
AC rated current																										
1A																										1
5A																										2
Outline																										
Standard LCD, 1/1 x 19" rack for flush/rack mounting																										4
Large LCD, 1/1 x 19" rack for flush/rack mounting																										8
Terminal block for BIO and PWS																										
Compression plug type terminal																										0
BI/BO module																										
Choice from BI/BO table																										
1×BIO module																										1 *
2×BIO modules																										2 *
3×BIO modules																										3 *
4×BIO modules																										4 *
5×BIO modules																										5 *
6×BIO modules																										6 *
7×BIO modules																										7 *
8×BIO modules																										8 *
Terminal block for BIO and PWS																										
Ring type terminal																										1
BI/BO module																										
Choice from BI/BO table																										
1×BIO module																										1 *
2×BIO modules																										2 *
3×BIO modules																										3 *
4×BIO modules																										4 *
5×BIO modules																										5 *

[Hardware selection] Double VCT Module Model for Software '31', '32', '34' and '35'

							Positions																						
							-	7	8	-	9	A	B	-	C	D	-	E	F	-	G	H	-	J	K	L			
Configurations							G	B	U	2	0	0	-			-													0
Number of Serial and/or Ethernet Communication and/or Time Synch Port(s)																													
and/or usage of extension IO unit (GIO200)																													
Refer to Communication port Table (See(*2))																													
Function Block (linked with software selection)																													
See function table of software selection																													

[Software selection]

							Positions																		
							-	7	S	G	N	-	E	F	U	-	9	V							
Configurations (BCPU: BCU with Protection)							G	B	U	2	0	0	-	4	0	3	1, 2, 4 or 5	-					-	4 or 8	E

							Positions																		
							-	7	S	G	N	-	E	F	U	-	9	V							
Configurations (BCU: BCU without Protection)							G	B	U	2	0	0	-	5 or 6	0	3	1, 2, 4 or 5	-					-	4 or 8	E

(*1) Binary inputs are intended for use with DC power source only.

The power supply supervision function is intended for use with DC power source only. It should be disabled when AC power supply is applied in order to prevent spurious alarms.

(*2) For PRP/HSR/RSTP protocol with IEC 61850, choose “L”, “N”, “P” or “R” code at position E. For hot/standby configuration or single port configuration with IEC 61850, choose other codes at position E.

Please contact with our sales staffs when you require user configurable models that are not indicated in the ordering sheet above.

[Hardware selection] Interface Model for Software '39'

	Positions																											
	G	B	U	2	0	0	-	7	8	-	9	A	B	-	C	D	-	E	F	-	G	H	-	J	K	L		
Configurations	G	B	U	2	0	0	-	0							-	0	0	-				-	3	0	-	0	0	0
Application of power system																												
BCU without Power Quantity Metering																												
No VCT module																												
DC rated voltage																												
110-250 Vdc or 100-220Vac (See (*1))																												
24/48/60 Vdc																												
System Frequency																												
N/A																												
AC rated current																												
N/A																												
Outline																												
Standard LCD,1/3 case×19"rack for flush mounting																												
Standard LCD,1/3 case×19"rack for rack mounting (See (*2))																												
Terminal block for BIO and PWS																												
Compression plug type terminal																												
BI/BO module																												
Choice from BI/BO table																												
Choice from BI/BO table																												
Number of Serial and/or Ethernet Communication and/or Time Synch Port(s)																												
Refer to Communication port Table (See(*3))																												
Function Block (linked with software selection)																												
See function table of software selection																												

[Software selection]

	Positions																	
	G	B	U	2	0	0	-	7	S	G	N	-	E	F	U	-	9	V
Configurations (Interface Model)	G	B	U	2	0	0	-	0	0	3	9	-				-	1 or E	E

- (*1) Binary inputs are intended for use with DC power source only.
The power supply supervision function is intended for use with DC power source only. It should be disabled when AC power supply is applied in order to prevent spurious alarms.
- (*2) For 19" rack panel mounting, accessories of joint kits are available. (See Figure 10)
EP-204 for single 1/2 x 19" size rack, EP-205 for two 1/2 x 19" size racks and EP-206 for single 3/4 x 19" size rack.
- (*3) For PRP/HSR/RSTP protocol with IEC 61850, choose "L", "N", "P" or "R" code at position E. For hot/standby configuration or single port configuration with IEC 61850, choose other codes at position E.

Please contact with our sales staffs when you require user configurable models that are not indicated in the ordering sheet above.

Number of BI/BO

BI/BO 1 x I/O module

Number of BI/BO									Ordering No. (Position "A" to "B")	Configuration
Independent BI	Independent BI (variable)	Common BI	DC-AI	Fast-BO	Semi-fast BO	BO	Hybrid BO	DC-AO		
7	-	-	-	-	6	4	-	-	11	1xBIO1
12	-	-	-	-	3	2	-	-	12	1xBIO2
8	-	-	-	6	-	2	-	-	13	1xBIO3
18	-	-	-	-	-	-	-	-	15	1xBI1
-	12	-	-	-	-	-	-	-	16	1xBI2
-	-	32	-	-	-	-	-	-	17	1xBI3
-	-	-	-	-	6	12	-	-	18	1xBO1

BI/BO 2 x I/O module

Number of BI/BO									Ordering No. (Position "A" to "B")	Configuration
Independent BI	Independent BI (variable)	Common BI	DC-AI	Fast-BO	Semi-fast BO	BO	Hybrid BO	DC-AO		
-	-	32	-	-	6	12	-	-	21	1xBI3+1xBO1
7	-	32	-	-	6	4	-	-	22	1xBI3+1xBIO1
12	-	32	-	-	3	2	-	-	23	1xBI3+1xBIO2
18	-	-	-	-	6	12	-	-	24	1xBI1+1xBO1
25	-	-	-	-	6	4	-	-	25	1xBI1+1xBIO1
30	-	-	-	-	3	2	-	-	26	1xBI1+1xBIO2
8	-	-	-	6	6	14	-	-	27	1xBO1+1xBIO3
15	-	-	-	6	6	6	-	-	28	1xBIO1+1xBIO3
7	-	-	-	-	12	16	-	-	29	1xBO1+1xBIO1
16	-	-	-	12	-	4	-	-	2A	2xBIO3
-	-	32	-	-	-	-	16	-	2B	1xBI3+1xBO2
-	12	-	-	-	6	12	-	-	2C	1xBI2 +1xBO1
-	-	32	10	-	-	-	-	-	2D	1xBI3+1xDCAI2
20	-	-	-	6	3	4	-	-	2E	1xBIO2+1xBIO3
12	-	-	-	-	9	14	-	-	2F	1xBO1+1xBIO2
8	12	-	-	6	-	2	-	-	2G	1xBI2+1xBIO3

BI/BO 3 x I/O module

Number of BI/BO									Ordering No. (Position "A" to "B")	Configuration
Independent BI	Independent BI (variable)	Common BI	DC-AI	Fast-BO	Semi-fast BO	BO	Hybrid BO	DC-AO		
15	-	-	-	6	12	18	-	-	31	1xBO1+1xBIO1+1xBIO3
20	-	-	-	6	9	16	-	-	32	1xBO1+1xBIO2+1xBIO3
23	-	-	-	12	6	8	-	-	33	1xBIO1+2xBIO3
26	-	-	-	6	6	14	-	-	34	1xBI1+1xBO1+1xBIO3
8	-	32	-	6	6	14	-	-	35	1xBI3+1xBO1+1xBIO3
24	-	-	-	18	-	6	-	-	36	3xBIO3
25	-	-	-	-	12	16	-	-	37	1xBI1+1xBO1+1xBIO1
-	-	32	10	-	6	12	-	-	38	1xBI3+1xDCAI2+1xBO1
36	-	-	-	-	6	12	-	-	39	2xBI1+1xBO1
-	24	-	-	-	6	12	-	-	3A	2xBI2+1xBO1
7	-	32	-	-	6	4	16	-	3C	1xBI3+1xBIO1+1xBO2
7	-	32	-	-	12	16	-	-	3D	1xBI3+1xBO1+1xBIO1
-	-	32	-	-	6	12	16	-	3E	1xBI3+1xBO1+1xBO2
18	-	-	10	-	6	12	-	-	3F	1xBI1+1xDCAI2+1xBO1
16	-	-	-	12	6	16	-	-	3G	1xBO1+2xBIO3
26	-	-	-	6	6	14	-	-	3J	1xBO1+1xBIO3+1xBI1
-	-	64	-	-	6	12	-	-	3K	2xBI3+1xBO1
14	-	32	-	-	12	8	-	-	3L	1xBI3+2xBIO1
-	-	96	-	-	-	-	-	-	3M	3xBI3
8	12	-	-	6	6	14	-	-	3N	1xBI2+1xBO1+1xBIO3
-	-	32	-	-	12	24	-	-	3P	1xBI3 + 2xBO1
8	-	32	-	6	6	14	-	-	3Q	1xBO1+1xBIO3+1xBI3 (*2)
-	-	-	30	-	-	-	-	-	3R	3xDCAI2
16	12	-	-	12	-	4	-	-	3S	1xBI2+2xBIO3
18	12	-	-	-	6	12	-	-	3T	1xBI1+1xBI2+1xBO1
12	-	32	-	-	9	14	-	-	3U	1xBI3+1xBO1+1xBIO2

Note:

*1: 3J: Special configuration. The boards combination is same as "34"

*2: 3Q: Special configuration. The boards combination is same as "35"

BI/BO 4 x I/O modules

Number of BI/BO									Ordering No. (Position "A" to "B")	Configuration
Independent BI	Independent BI (variable)	Common BI	DC-AI	Fast-BO	Semi-fast BO	BO	Hybrid BO	DC-AO		
26	-	-	-	6	12	26	-	-	41	1xBI1+2xBO1+1xBIO3
32	-	-	-	24	-	8	-	-	42	4xBIO3
8	-	32	-	6	12	26	-	-	43	1xBI3+2xBO1+1xBIO3
-	-	64	-	-	12	24	-	-	44	2xBI3+2xBO1
8	-	32	10	6	6	14	-	-	45	1xBI3+1xDCAI2+1xBO1+1xBIO3
54	-	-	-	-	6	12	-	-	46	3xBI1+1xBO1
20	-	32	-	6	9	16	-	-	47	1xBI3+1xBO1+1xBIO2+1xBIO3
26	-	-	-	6	12	26	-	-	48	1xBO1+1xBI1+1xBO1+1xBIO3
20	-	-	-	6	15	28	-	-	49	2xBO1+1xBIO2+1xBIO3
-	-	64	10	-	6	12	-	-	4A	2xBI3+1xDCAI2+1xBO1
34	-	-	-	12	6	16	-	-	4B	1xBI1+1xBO1+2xBIO3
-	-	64	-	-	-	-	32	-	4C	2xBI3+2xBO2
21	-	32	-	-	18	12	-	-	4D	1xBI3+3xBIO1
-	-	128	-	-	-	-	-	-	4E	4xBI3
7	-	96	-	-	6	4	-	-	4F	3xBI3+1xBIO1
8	24	-	-	6	6	14	-	-	4G	2xBI2+1xBO1+1xBIO3
-	-	32	-	-	18	36	-	-	4H	1xBI3+3xBO1
26	12	-	-	6	6	14	-	-	4J	1xBI1+1xBI2+1xBO1+1xBIO3
24	-	32	-	-	12	16	-	-	4K	1xBI3+1xBO1+2xBIO2
15	-	-	-	6	18	30	-	-	4L	2xBO1+1xBIO1+1xBIO3
7	-	-	-	-	24	40	-	-	4M	3xBO1+1xBIO1
36	-	-	-	-	12	24	-	-	4N	2xBI1+2xBO1
8	-	64	-	6	6	14	-	-	4P	2xBI3+1xBO1+1xBIO3
36	-	-	-	-	6	12	16	-	4Q	2xBI1+1xBO1+1xBO2
44	-	-	-	6	6	14	-	-	4R	2xBI1+1xBO1+1xBIO3
12	-	64	10	-	3	2	-	-	4S	2xBI3+1xDCAI2+1xBIO2
-	-	64	20	-	-	-	-	-	4T	2xBI3+2xDCAI2

BI/BO 5 x I/O modules

Number of BI/BO									Ordering No. (Position "A" to "B")	Configuration
Independent BI	Independent BI (variable)	Common BI	DC-AI	Fast-BO	Semi-fast BO	BO	Hybrid BO	DC-AO		
33	-	-	-	6	6	6	32	-	51	1xBI1+1xBIO1+1xBIO3+2xBO2
44	-	-	-	6	12	26	-	-	52	2xBI1+2xBO1+1xBIO3
25	-	96	-	-	6	4	-	-	53	1xBI1+3xBI3+1xBIO1
8	-	96	-	6	6	14	-	-	54	3xBI3+1xBO1+1xBIO3
-	-	64	10	-	12	24	-	-	55	2xBI3+1xDCAI2+2xBO1
62	-	-	-	6	6	14	-	-	56	3xBI1+1xBO1+1xBIO3
54	-	-	10	-	6	12	-	-	58	3xBI1+1xDCAI2+1xBO1
36	-	-	10	-	12	24	-	-	59	2xBI1+1xDCAI2+2xBO1
20	-	32	10	6	9	16	-	-	5A	1xBI3+1xDCAI2+1xBO1+1xBIO2+1xBIO3
-	-	96	-	-	12	24	-	-	5B	3xBI3+2xBO1
-	-	96	10	-	6	12	-	-	5C	3xBI3+1xDCAI2+1xBO1
-	-	64	10	-	-	-	32	-	5D	2xBI3+1xDCAI2+2xBO2
-	-	128	-	-	6	12	-	-	5E	4xBI3+1xBO1
-	-	160	-	-	-	-	-	-	5F	5xBI3
44	12	-	-	6	6	14	-	-	5G	2xBI1+1xBI2+1xBO1+1xBIO3
15	-	-	-	6	24	42	-	-	5H	3xBO1+1xBIO1+1xBIO3
-	-	64	-	-	18	36	-	-	5J	2xBI3+3xBO1
7	-	96	10	-	6	4	-	-	5K	3xBI3+1xDCAI2+1xBIO1
-	-	-	-	-	30	60	-	-	5L	5xBO1
-	-	64	30	-	-	-	-	-	5M	2xBI3+3xDCAI2
-	-	96	20	-	-	-	-	-	5N	3xBI3+2xDCAI2
42	-	-	-	18	6	18	-	-	5P	1xBI1+1xBO1+3xBIO3
41	-	-	-	12	12	20	-	-	5Q	1xBI1+1xBO1+1xBIO1+2xBIO3
8	-	64	-	6	-	2	32	-	5R	2xBI3+1xBIO3+2xBO2
8	12	64	0	6	-	2	16	-	5S	1xBI2+2xBI3+1xBIO3+1xBO2
-	-	32	30	-	6	12	-	-	5T	1xBI3+3xDCAI2+1xBO1
36	24	-	-	-	6	12	-	-	5U	2xBI1+2xBI2+1xBO1

BI/BO 6 x I/O modules

Number of BI/BO									Ordering No. (Position "A" to "B")	Configuration
Independent BI	Independent BI (variable)	Common BI	DC-AI	Fast-BO	Semi-fast BO	BO	Hybrid BO	DC-AO		
51	-	-	-	6	18	30	-	-	61	2xBI1+2xBO1+1xBIO1+1xBIO3
8	-	96	-	6	12	26	-	-	62	3xBI3+2xBO1+1xBIO3
-	-	128	-	-	12	24	-	-	63	4xBI3+2xBO1
8	-	128	-	6	6	14	-	-	64	4xBI3+1xBO1+1xBIO3
8	-	96	10	6	6	14	-	-	65	3xBI3+1xDCAI2+1xBO1+1xBIO3
-	-	128	10	-	6	12	-	-	67	4xBI3+1xDCAI2+1xBO1
-	-	96	10	-	12	24	-	-	68	3xBI3+1xDCAI2+2xBO1
52	-	-	-	12	-	4	32	-	69	2xBI1+2xBIO3+2xBO2
52	-	-	-	12	12	28	-	-	6A	2xBI1+2xBO1+2xBIO3
36	-	-	-	-	24	48	-	-	6B	2xBI1+4xBO1
36	-	64	-	-	12	24	-	-	6C	2xBI1+2xBI3+2xBO1
44	-	-	-	6	18	38	-	-	6D	2xBI1+3xBO1+1xBIO3
-	-	160	-	-	6	12	-	-	6E	5xBI3+1xBO1
7	-	160	-	-	6	4	-	-	6F	5xBI3+1xBIO1
8	-	64	-	6	-	2	48	-	6G	2xBI3+1xBIO3+3xBO2
26	-	64	-	6	-	2	32	-	6H	1xBI1+2xBI3+1xBIO3+2xBO2
8	12	64	-	6	6	14	16	-	6J	1xBI2+2xBI3+1xBO1+1xBIO3+1xBO2
-	-	96	30	-	-	-	-	-	6K	3xBI3+3xDCAI2

BI/BO 7 x I/O modules

Number of BI/BO									Ordering No. (Position "A" to "B")	Configuration
Independent BI	Independent BI (variable)	Common BI	DC-AI	Fast-BO	Semi-fast BO	BO	Hybrid BO	DC-AO		
80	-	-	-	6	12	26	-	-	71	4xBI1+2xBO1+1xBIO3
8	-	96	-	6	18	38	-	-	73	3xBI3+3xBO1+1xBIO3
-	-	96	20	-	12	24	-	-	76	3xBI3+2xDCAI2+2xBO1
7	-	64	20	-	6	4	32	-	77	2xBI3+2xDCAI2+1xBIO1+2xBO2
-	60	-	-	-	6	12	16	-	78	5xBI2+1xBO1+1xBO2
-	-	160	-	-	12	24	-	-	79	5xBI3+2xBO1
52	-	-	10	12	12	28	-	-	7A	2xBI1+1xDCAI2+2xBIO3+2xBO1
54	-	64	-	-	12	24	-	-	7B	3xBI1 + 2xBI3 + 2xBO1
18	-	96	10	-	12	24	-	-	7C	1xBI1+3xBI3+1xDCAI2+2xBO1
-	-	128	-	-	18	36	-	-	7D	4xBI3+3xBO1
7	-	160	-	-	12	16	-	-	7E	5xBI3+1xBO1+1xBIO1
-	-	192	-	-	6	12	-	-	7F	6xBI3+1xBO1
7	-	192	-	-	6	4	-	-	7G	6xBI3+1xBIO1
-	-	224	-	-	-	-	-	-	7H	7xBI3
26	-	64	20	6	6	14	-	-	7J	1xBI1+2xBI3+2xDCAI2+1xBO1+1xBIO3
-	-	128	30	-	-	-	-	-	7K	4xBI3+3xDCAI2
8	-	96	-	6	-	2	48	-	7L	3xBI3+1xBIO3+3xBO2
-	-	160	10	-	6	12	-	-	7M	5xBI3+1xDCAI+1xBO1

BI/BO 8 x I/O modules

Number of BI/BO									Ordering No. (Position "A" to "B")	Configuration
Independent BI	Independent BI (variable)	Common BI	DC-AI	Fast-BO	Semi-fast BO	BO	Hybrid BO	DC-AO		
-	-	128	10	-	18	36	-	-	81	4xBI3+1xDCAI2+3xBO1
-	-	160	-	-	18	36	-	-	83	5xBI3+3xBO1
-	-	160	20	-	6	12	-	-	84	5xBI3+2xDCAI2+1xBO1
-	-	192	10	-	6	12	-	-	85	6xBI3+1xDCAI2+1xBO1
-	-	96	10	-	24	48	-	-	86	3xBI3+1xDCAI2+4xBO1
-	60	-	-	-	6	12	32	-	87	5xBI2+1xBO1+2xBO2
8	-	128	-	6	18	38	-	-	88	4xBI3+3xBO1+1xBIO3
14	-	96	30	-	12	8	-	-	89	3xBI3+3xDCAI2+2xBIO1
-	-	128	20	-	12	24	-	-	8A	4xBI3+2xDCAI2+2xBO1
-	-	192	20	-	-	-	-	-	8B	6xBI3+2xDCAI2
-	-	256	-	-	-	-	-	-	8C	8xBI3
36	-	64	20	-	12	24	-	-	8D	2xBI1+2xBI3+2xDCAI2+2xBO1
18	-	96	10	-	18	36	-	-	8E	1xBI1+3xBI3+1xDCAI2+3xBO1
-	-	128	10	-	-	-	48	-	8F	4xBI3+1xDCAI2+3xBO2
7	-	224	-	-	6	4	-	-	8G	7xBI3+1xBIO1
-	-	192	-	-	12	24	-	-	8H	6xBI3+2xBO1
7	-	192	-	-	12	16	-	-	8J	6xBI3+1xBO1+1xBIO1
21	-	96	10	-	24	24	-	-	8K	3xBI3+1xDCAI2+1xBO1+3xBIO1
-	-	128	30	-	6	12	-	-	8L	4xBI3+3xDCAI2+1xBO1
7	-	96	-	-	30	52	-	-	8M	3xBI3+4xBO1+1xBIO1
-	-	128	-	-	24	48	-	-	8N	4xBI3+4xBO1
12	-	128	10	-	15	26	-	-	8P	4xBI3+1xDCAI2+2xBO1+1xBIO2
12	-	160	20	-	3	2	-	-	8R	5xBI3+2xDCAI2+1xBIO2

Communication port Table

Positions		Number of Ethernet, Time Synch, and GIO					
E	F	100Base-FX	100Base-TX /1000Base-T	1000base-LX	IRIG-B	GIO200	Remark
1	K	-	-	1	-	-	
3	K	-	-	1	1	-	
B	K	-	-	1	-	1	
D	K	-	-	1	1	1	
4	M	-	-	2	-	-	Hot/Standby
6	M	-	-	2	1	-	
B	M	-	-	2	-	1	
D	M	-	-	2	1	1	
L	M	-	-	2	-	-	PRP/HSP/RSTP
N	M	-	-	2	1	-	
P	M	-	-	2	-	1	
R	M	-	-	2	1	1	
1	J	-	1	-	-	-	
3	J	-	1	-	1	-	
B	J	-	1	-	-	1	
D	J	-	1	-	1	1	
4	L	-	2	-	-	-	Hot/Standby
6	L	-	2	-	1	-	
B	L	-	2	-	-	1	
D	L	-	2	-	1	1	
L	L	-	2	-	-	-	PRP/HSP/RSTP
N	L	-	2	-	1	-	
P	L	-	2	-	-	1	
R	L	-	2	-	1	1	
1	4	1	-	-	-	-	
3	4	1	-	-	1	-	
B	4	1	-	-	-	1	
D	4	1	-	-	1	1	
4	6	2	-	-	-	-	Hot/Standby
6	6	2	-	-	1	-	
B	6	2	-	-	-	1	
D	6	2	-	-	1	1	
L	6	2	-	-	-	-	PRP/HSP/RSTP
N	6	2	-	-	1	-	
P	6	2	-	-	-	1	
R	6	2	-	-	1	1	

[Software selection]

	1	2	3	4	5	6	7	S	G	N	E	F	U	9	V	
Configurations	G	B	U	2	0	0	-	0			-			-		
Application of power system																
Assignment on position "7"																
Function Block																
Refer to Function Table																
Communication for Remote / Time Synch. (1)																
Assignment on position "E" (See (*1))																
Communication for Remote / Time Synch. (2)																
Assignment on position "F" (See (*1))																
Protocol																
IEC61850													2			
Outline																
Assignment on position "9"																
Language																
English																E

(*1) For PRP/HSR/RSTP protocol with IEC 61850, choose "L", "N", "P" or "R" code at position E.
 For hot/standby configuration or single port configuration with IEC 61850, choose other codes at position E.

FUNCTION TABLE

Function Block		Description	Ordering No. (Position "G & N")				
			31	32	34	35	39
[Control function]							
Control (*1)	DPSY	Double position control with synchronizing checking	●	●	●	●	
	DPOS	Double position device control	●	●	●	●	●
	SPOS	Single position device control	●	●	●	●	●
	TPOS	Three position device control	●	●	●	●	
	TAP	TAP control (BCD)	●	●	●	●	
	TAP	TAP control (DCAI)	●	●	●	●	
	SOFTSW	Software switch controller	●	●	●	●	●
Interlock	ILK	Interlock	●	●	●	●	●
AutoSEQ	ASEQ	Automatic sequential control	●	●	●	●	
Monitoring	---	Monitoring	●	●	●	●	
---	DCB	Double command blocking	●	●	●	●	
---	DCAI	DC analog input measurement	○	○	○	○	
---	DCAO	DC analog output control		○		○	
---	SYNDIF	Synchrocheck between different network (e.g. between transmission line and generator plant)	●	●	●	●	
---	MNOVR (*2)	Manual override		●		●	
[Protection]							
50/67,51/67	OC	Non-directional / directional phase overcurrent protection (4 steps)			●	●	
50N/67N,51N/67N	EF	Non-directional / directional earth fault overcurrent protection (4 steps)			●	●	
50SEF/51SEF	SEF	Non-directional sensitive overcurrent protection (2 steps)			●	●	
46/67	OCN	Non-Directional / directional negative sequence phase over-current protection (4 steps)			●	●	
50BF	CBF	Circuit breaker failure protection (2 stages)			●	●	
37	UC	Phase under-current protection (2 steps)			●	●	
46BC	BCD	Broken conductor protection			●	●	
49	THM	Thermal overload protection			●	●	
---	CLP	Cold load protection			●	●	
59	OV	Phase over-voltage protection (4 steps)			●	●	
59N	OVG	Earth fault over-voltage protection (4 steps)			●	●	
47	OVN	Negative sequence phase over-voltage protection (4 steps)			●	●	
27	UV	Phase under-voltage protection (4 steps)			●	●	
81	FRQ	Frequency protection (6 steps)			●	●	
ROCOF	DFRQ	Rate of change of frequency (df/dt) (6 steps)			●	●	
51V	OCV	Voltage controlled/restraint overcurrent (4 steps)			●	●	
50SOTF	SOTF-OC	Switch on to fault protection			●	●	
21FL	FL	Fault locator			●	●	
---	ICD	Inrush current detection function (2f)			●	●	
79	ARC	Autoreclosing function (3 phase)			●	●	
25	VCHK	Voltage check for autoreclosing			●	●	
[Common]							
Event	---	Event and alarm	●	●	●	●	●
Measurement	---	Measurement	●	●	●	●	●
Counter	---	Counter	●	●	●	●	●
Communication	---	Remote communication	○	○	○	○	●
---	TCS	Trip circuit supervision	●	●	●	●	
---	VTF	VTF detection function	●	●	●	●	
---	CTF	CTF detection function	●	●	●	●	
---	PORQTY	Power quality monitoring	○	○	○	○	
---	PLC	Programmable logic controller	●	●	●	●	●
			Control without DCAO/MNOVR	Control	Control + Protection (without DCAO, MNOVR)	Control + Protection	Interface unit

●: Standard, ○: Equipped depending on the hardware configuration

*1: Maximum device number for control/tap (control/monitoring)

Function No.: 31, 32, 34, 35			
Device	Number	Device	Number
DPSY	2	TAP	4
DPOS	72	(Control & Monitoring)	
SPOS	20		
TPOS	24	TAP (only Monitoring)	12
SOFTSW	64		

Function No.: 39			
Device	Number	Device	Number
DPSY	-	TAP	-
DPOS	72	-	-
SPOS	20	-	-
TPOS	-	-	-
SOFTSW	64	-	-

*2: When "MNOVR" function is required, only 6, 7, 8, J & K (Large LCD) is selectable for column 9 of "Hardware Selection".

DIMENSION AND PANEL CUT-OUT (1/3 size)

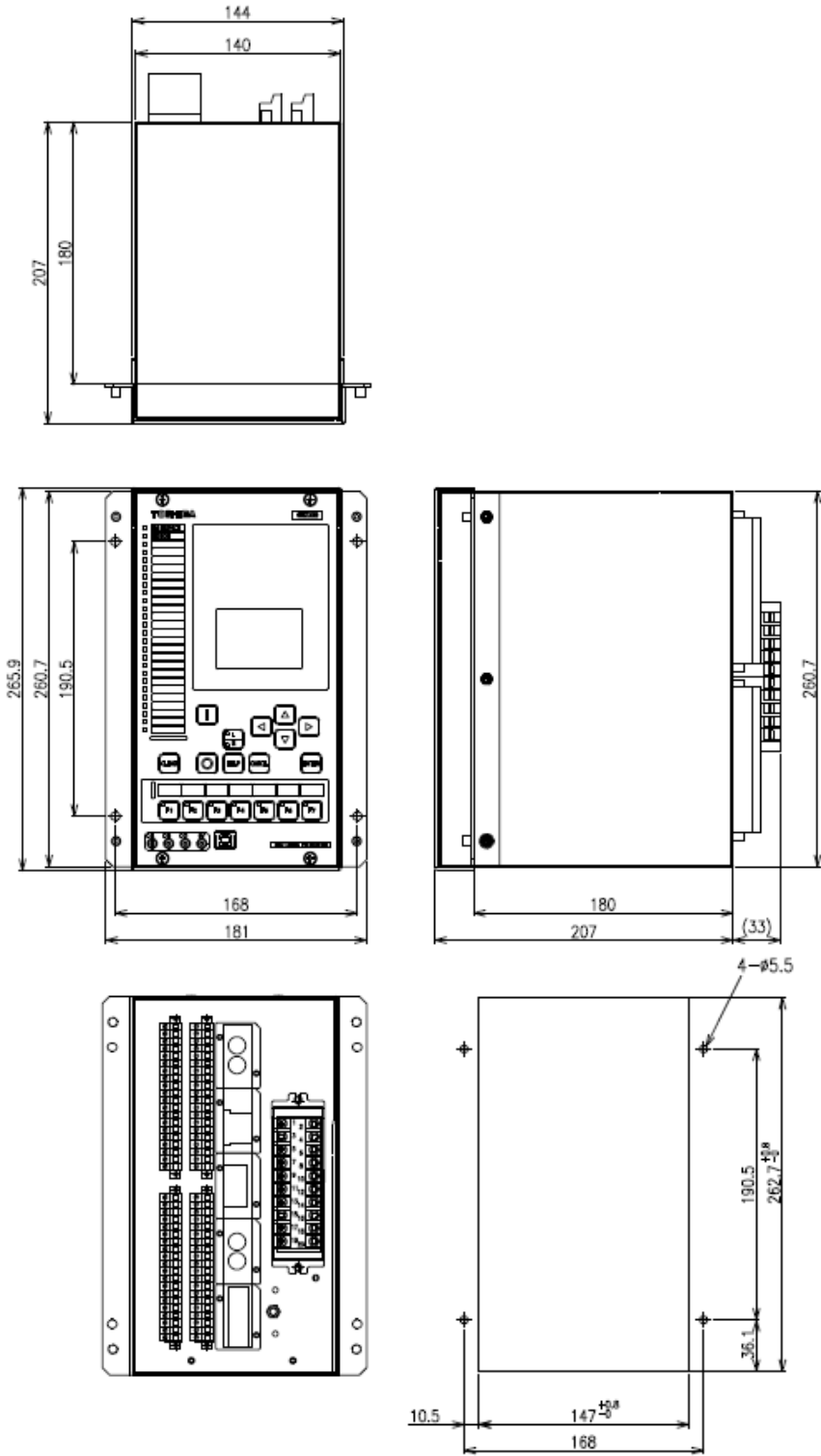

(Panel cut-out)

Note: For a rack mount unit, there are holes for joint kits assembling on top and bottom of the unit.

Figure 6 – Dimension and Panel Cut-out – 1/3 x 19'' case size

DIMENSION AND PANEL CUT-OUT (1/2 size)

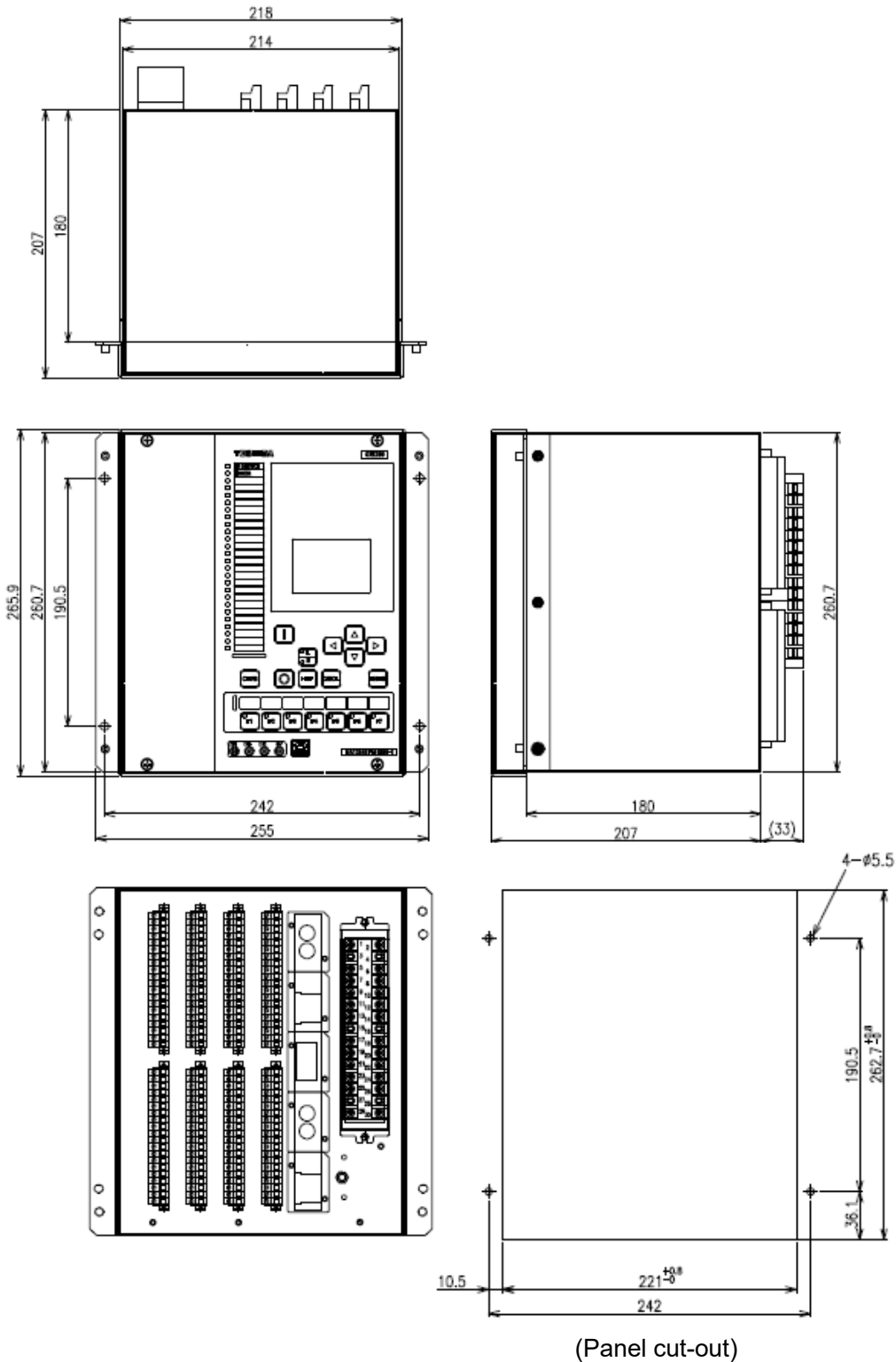

(Panel cut-out)

Note: For a rack mount unit, there are holes for joint kits assembling on top and bottom of the unit.

Figure 7 – Dimension and Panel Cut-out – 1/2 x 19” case size

DIMENSION AND PANEL CUT-OUT (3/4 size)

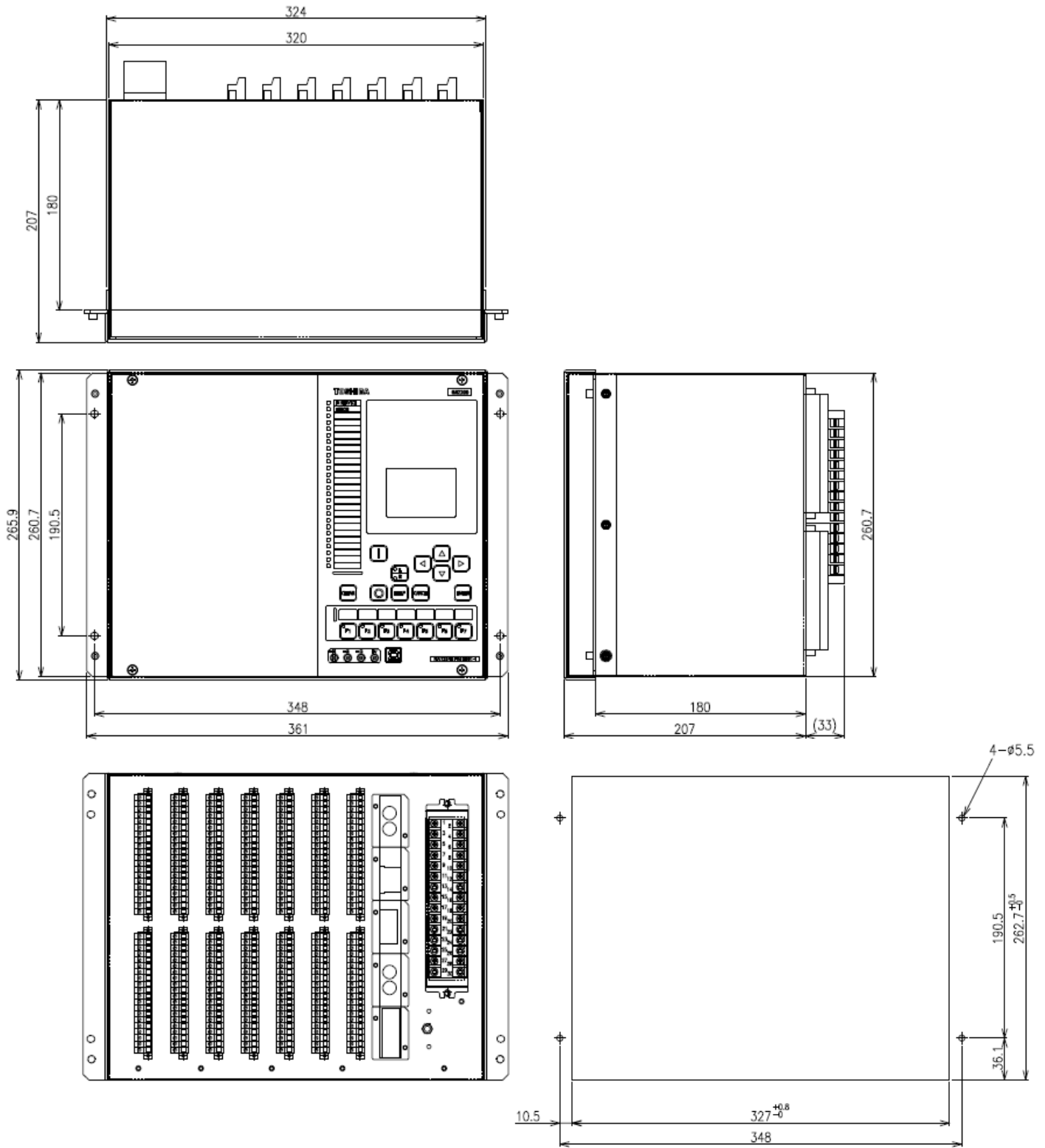

(Panel cut-out)

Note: For a rack mount unit, there are holes for joint kits assembling on top and bottom of the unit.

Figure 8 – Dimension and Panel Cut-out – 3/4 x 19" case size for flush mounting type

DIMENSION AND PANEL CUT-OUT (1/1 size)

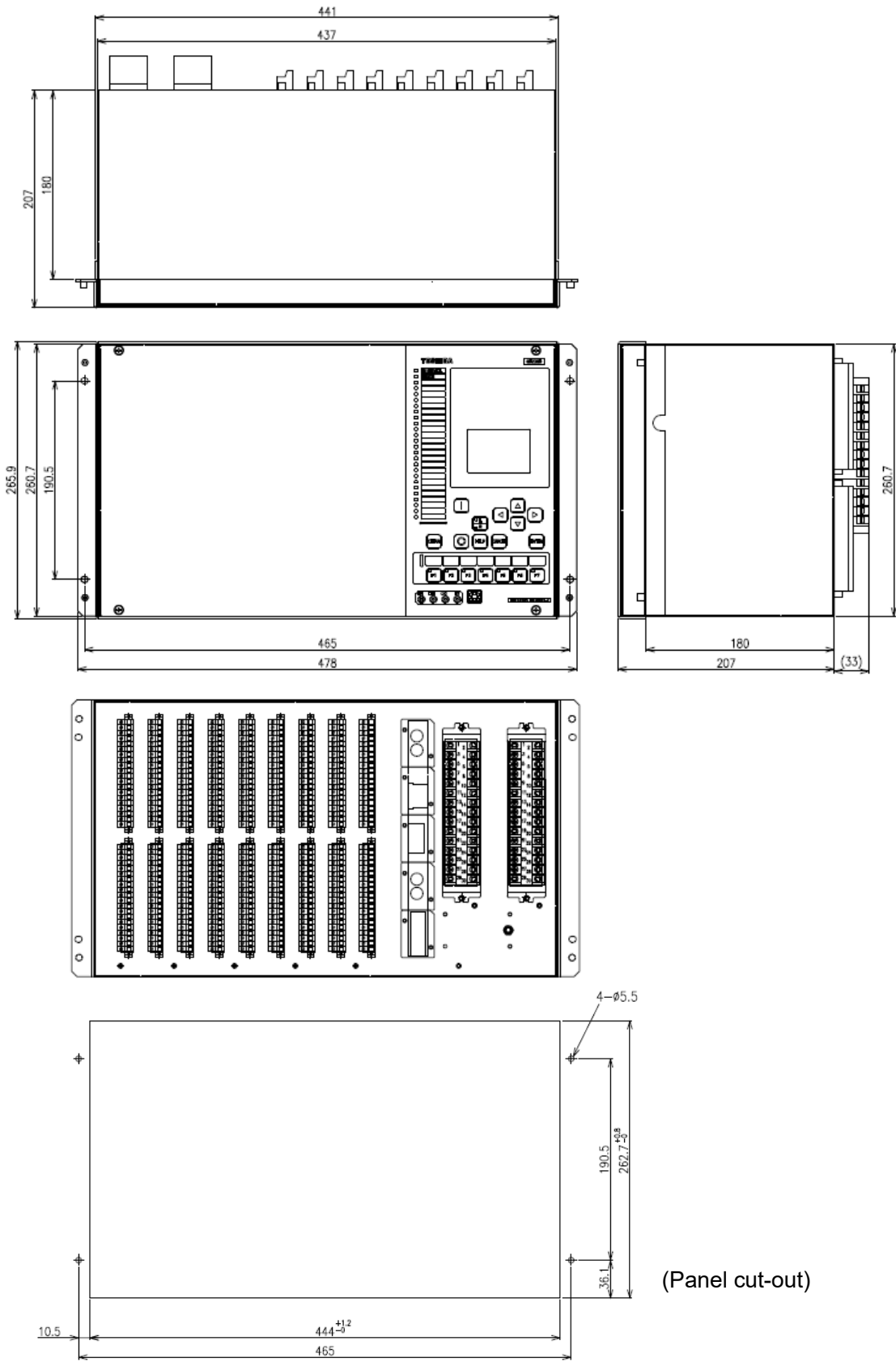

Note: For a rack mount unit, there are holes for joint kits assembling on top and bottom of the unit.

Figure 9 – Dimension and Panel Cut-out – 1/1 x 19” case size for flush mounting type

19" RACK MOUNTING JOINT KITS ATTACHMENT

<Panel mounting kits – only for compressed terminal type racks>

Name	Code
Joint kits for single 1/3 x 19" size rack	EP-201
Joint kits for two 1/3 x 19" size racks	EP-202
Joint kits for three 1/3 x 19" size racks	EP-203
Joint kits for single 1/2 x 19" size rack	EP-204
Joint kits for two 1/2 x 19" size racks	EP-205
Joint kits for single 3/4 x 19" size rack	EP-206

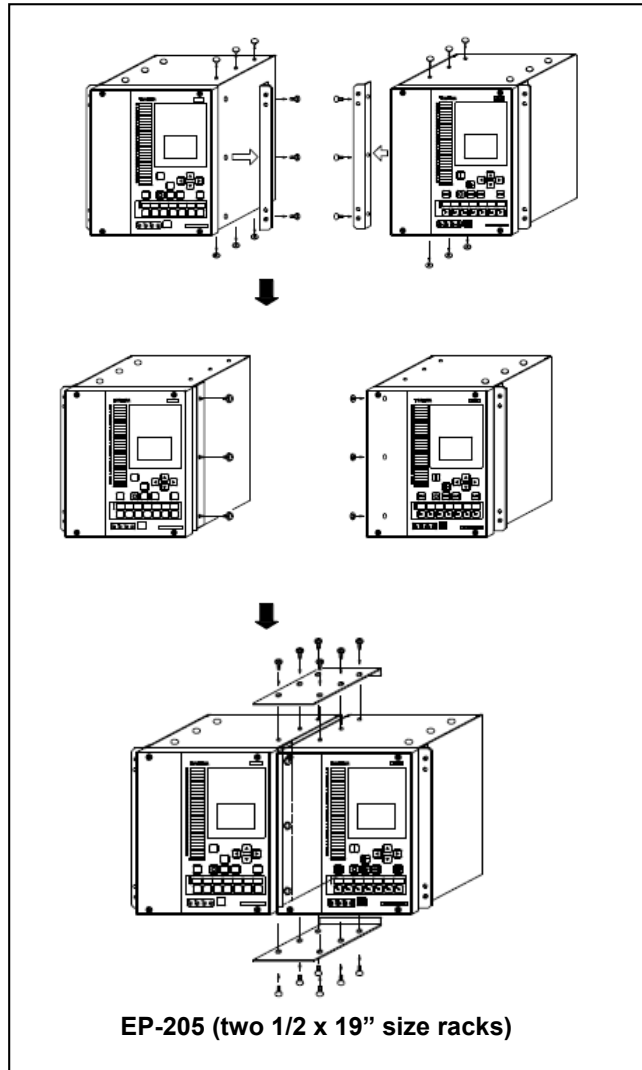
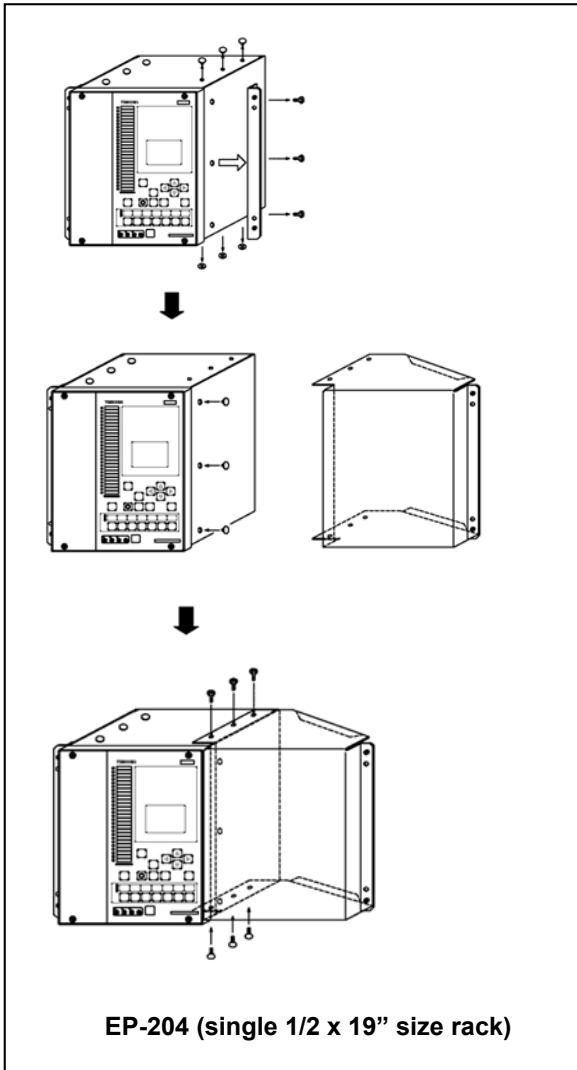
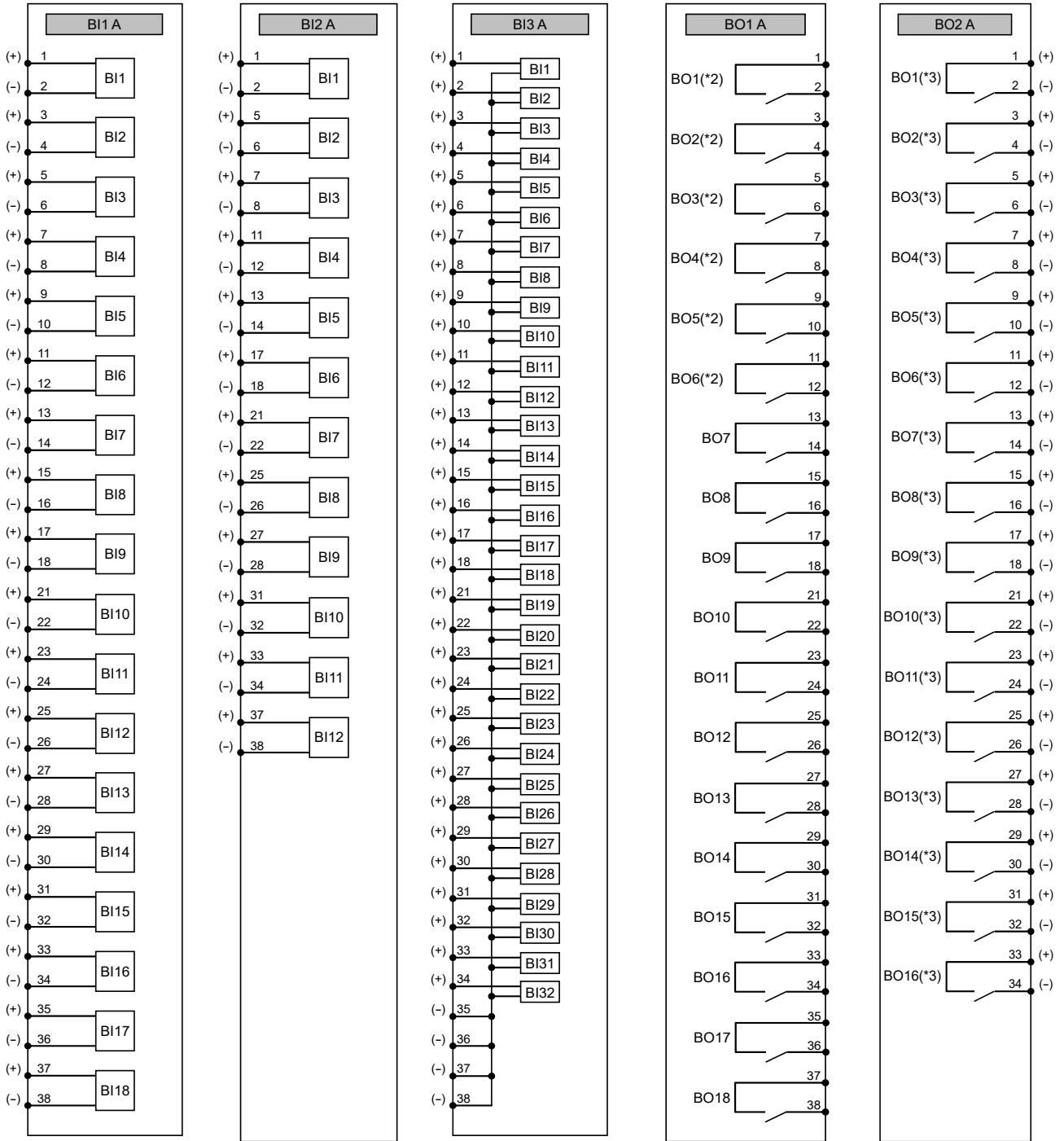

Figure 10 – Joint kits example for 19" rack panel mounting

CONNECTIONS DIAGRAM (COMPRESSION PLUG TYPE)



(*2) Semi-fast BO
 (*3) Hybrid BO

Figure 11 – Binary input board and binary output module

CONNECTIONS DIAGRAM (COMPRESSION PLUG TYPE)

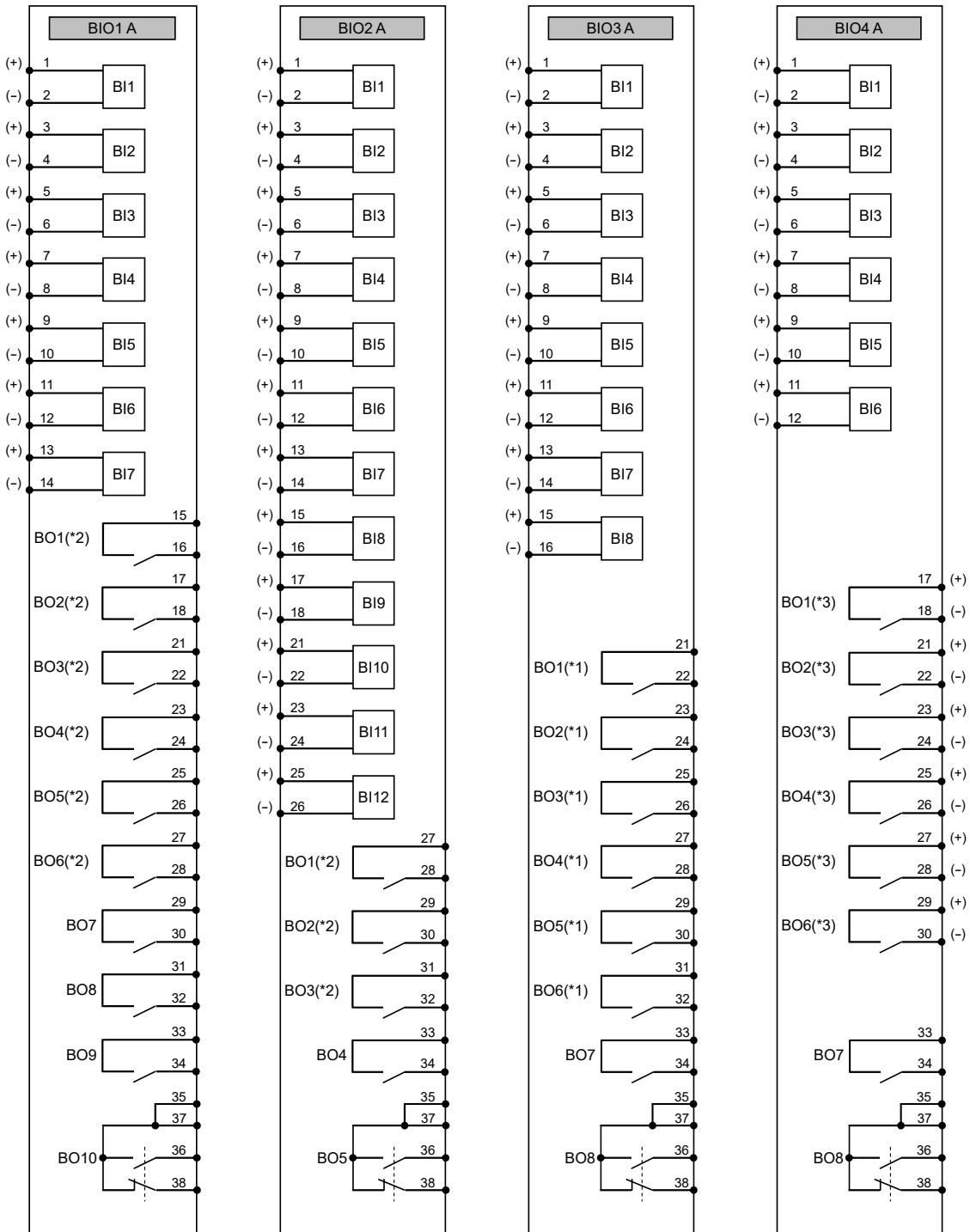

- (*1) Fast BO
- (*2) Semi-fast BO
- (*3) Hybrid BO

Figure 12 – Combined binary input and output module

CONNECTIONS DIAGRAM (COMPRESSION PLUG TYPE)

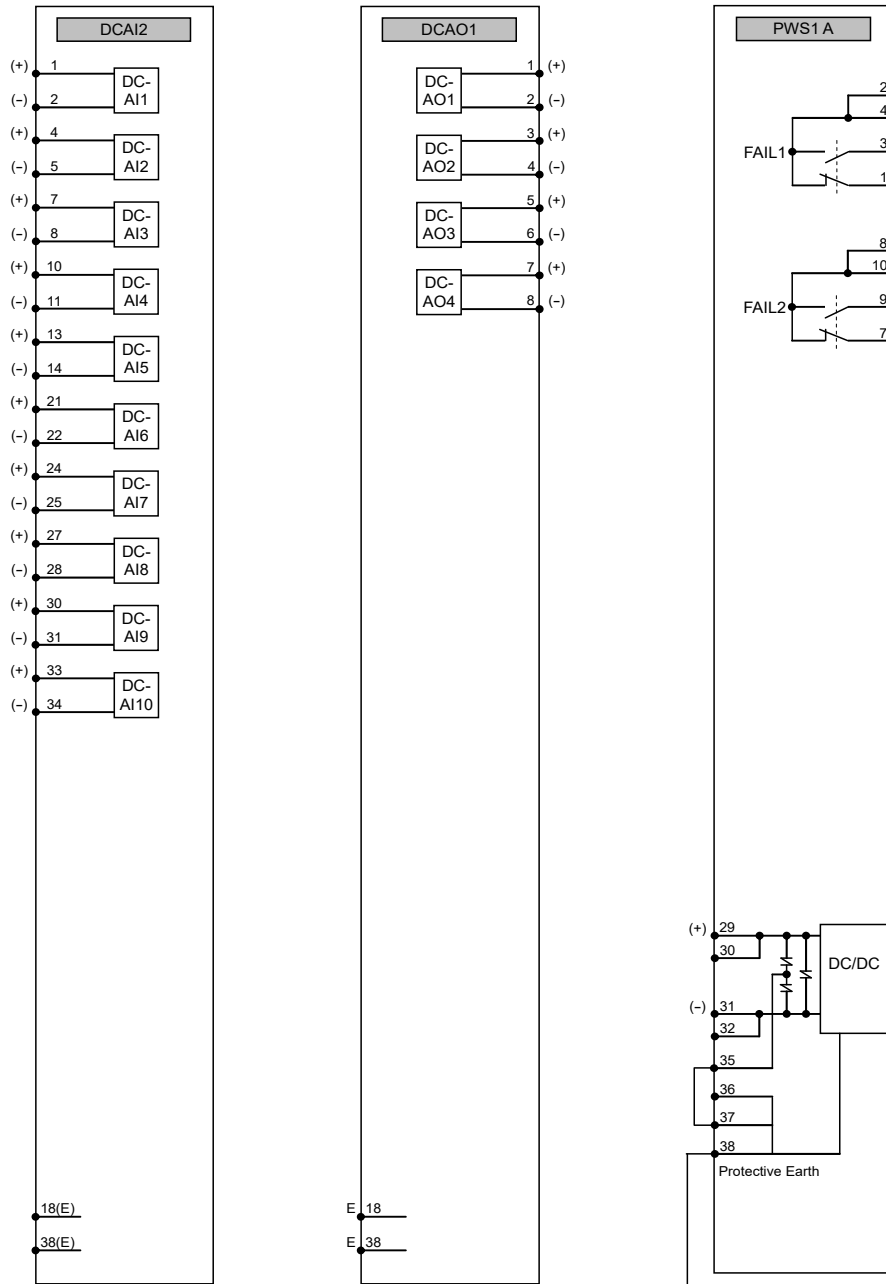

Figure 13 – DC-analogue input and output module and DC/DC module

CONNECTIONS DIAGRAM

CT/VT module

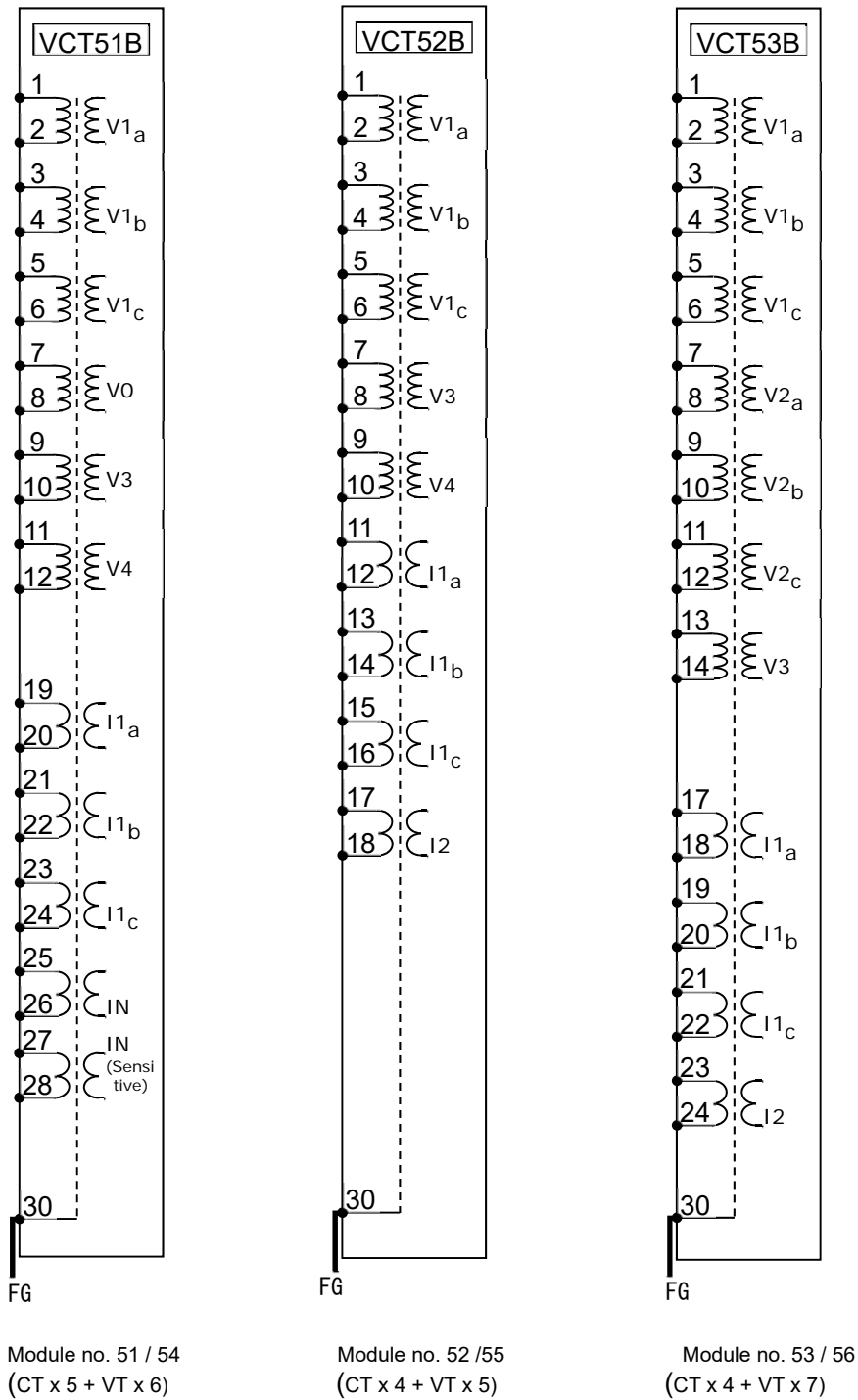

Figure 14 – CT/VT module

EXTERNAL CONNECTIONS DIAGRAM

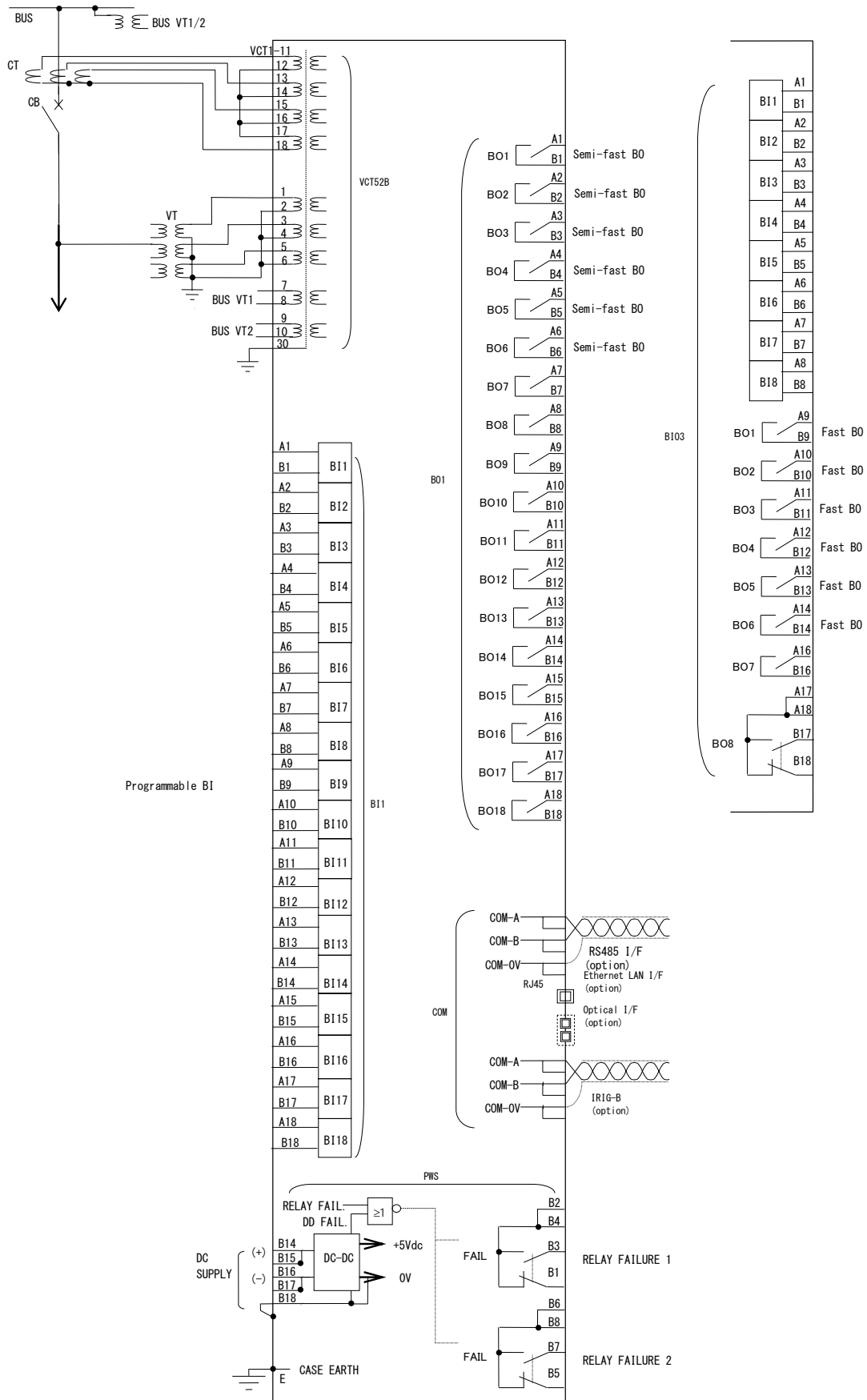

Figure 15 – Typical external connection diagram – ring terminal type (VCT: No.52, IO: B11, BO1 and B103)

ORDERING SHEET for External IO Unit - GIO200

[Hardware selection]

										Positions																					
										-	7	8	-	9	A	B	-	C	D	-	E	F	-	G	H	-	J	K	L		
Configurations										G	I	O	2	0	0	-	0	-	-	-	0	0	-	0	0	-	3	-	0	0	0
DC rated voltage																															
110-250 Vdc or 100-220Vac (See (*1))										1																					
24/48/60 Vdc										3																					
Outline																															
1/2 case×19" rack for flush mounting										U																					
1/2 case×19" rack for rack mounting										V																					
Terminal block for BIO and PWS																															
Compression plug type terminal										0																					
BI/BO module																															
Choice from BI/BO table										1×BIO module		1		*																	
Choice from BI/BO table										2×BIO module		2		*																	
Choice from BI/BO table										3×BIO module		3		*																	
Terminal block for BIO and PWS																															
Ring type terminal										1																					
BI/BO module																															
Choice from BI/BO table										1×BIO module		1		*																	
Choice from BI/BO table										2×BIO module		2		*																	
Outline																															
1/1 case×19" rack for rack/flush mounting										W																					
Terminal block for BIO and PWS																															
Compression plug type terminal										0																					
BI/BO module																															
Choice from BI/BO table										1×BIO module		1		*																	
Choice from BI/BO table										2×BIO module		2		*																	
Choice from BI/BO table										3×BIO module		3		*																	
Choice from BI/BO table										4×BIO module		4		*																	
Choice from BI/BO table										5×BIO module		5		*																	
Choice from BI/BO table										6×BIO module		6		*																	
Choice from BI/BO table										7×BIO module		7		*																	
Terminal block for BIO and PWS																															
Ring type terminal										1																					
BI/BO module																															
Choice from BI/BO table										1×BIO module		1		*																	
Choice from BI/BO table										2×BIO module		2		*																	
Choice from BI/BO table										3×BIO module		3		*																	
Choice from BI/BO table										4×BIO module		4		*																	
Choice from BI/BO table										5×BIO module		5		*																	
Choice from BI/BO table										6×BIO module		6		*																	
Choice from BI/BO table										7×BIO module		7		*																	

[Software selection]

No need specified.

Number of I/O for GIO200

I/O module

Number of BI/BO									Ordering No. (Position "A" to "B")	Configuration
Independent BI	Independent BI (variable)	Common BI	DC-AI	Fast-BO	Semi-fast BO	BO	Heavy duty BO	DC-AO		
-	-	32	-	-	-	-	-	-	17	1xBI3
-	-	32	10	-	-	-	-	-	2D	1xBI3+1xDCAI2
-	-	-	30	-	-	-	-	-	3R	3xDCAI2
-	-	64	20	-	-	-	-	-	4T	2xBI3+2xDCAI2
-	-	64	-	-	18	36	-	-	5J	2xBI3+3xBO1
-	-	-	-	-	30	60	-	-	5L	5xBO1
-	-	64	30	-	-	-	-	-	5M	2xBI3+3xDCAI2
-	-	96	20	-	-	-	-	-	5N	3xBI3+2xDCAI2
-	-	32	30	-	6	12	-	-	5T	1xBI3+3xDCAI2+1xBO1
-	-	96	30	-	-	-	-	-	6K	3xBI3+3xDCAI2
-	-	128	30	-	-	-	-	-	7K	4xBI3+3xDCAI2

DIMENSION AND PANEL CUT-OUT (1/2 size) of GIO200

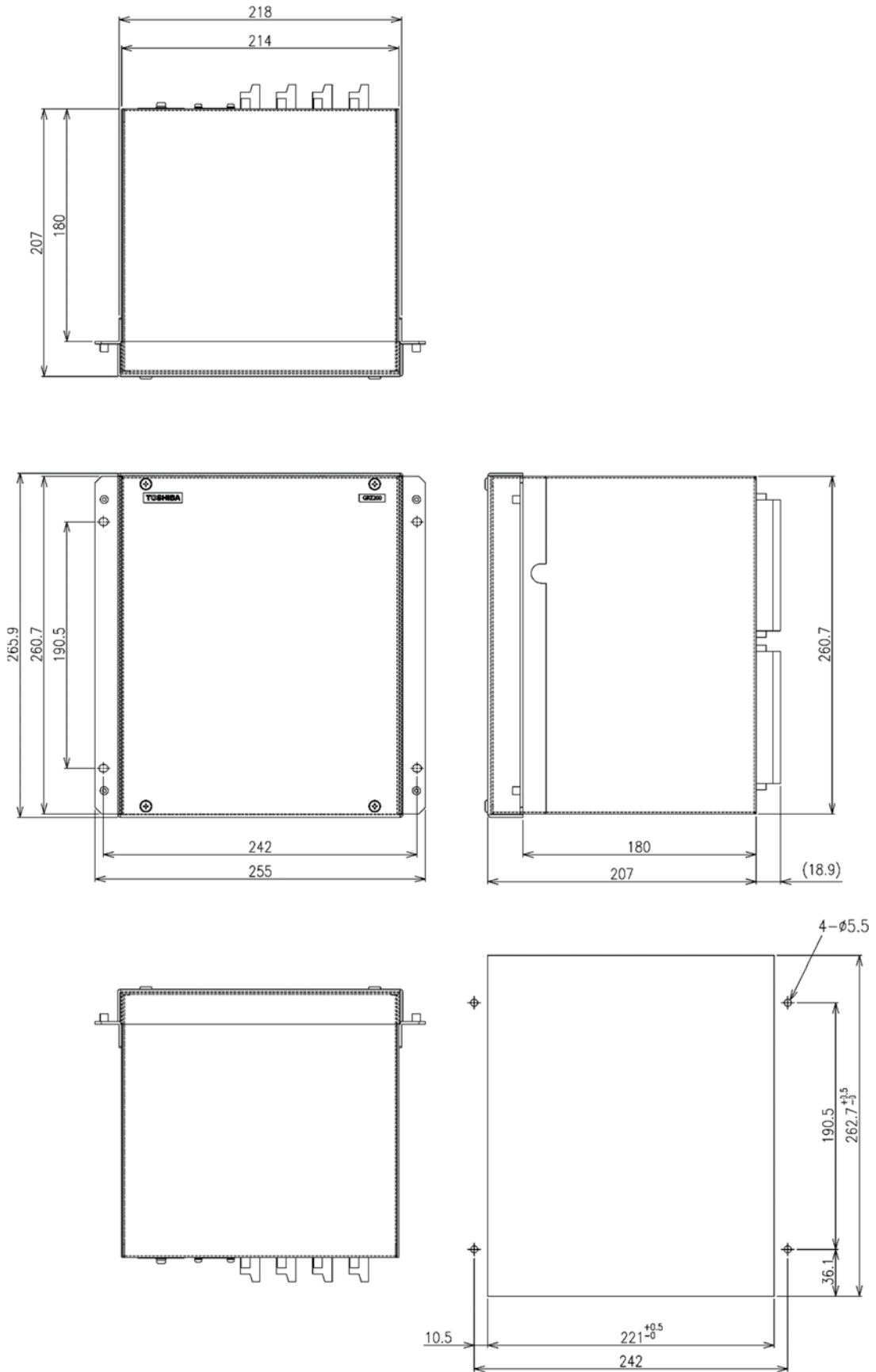

Figure 16 – Dimension and Panel Cut-out – 1/2 x 19” case size

DIMENSION AND PANEL CUT-OUT (1/1 size) of GIO200

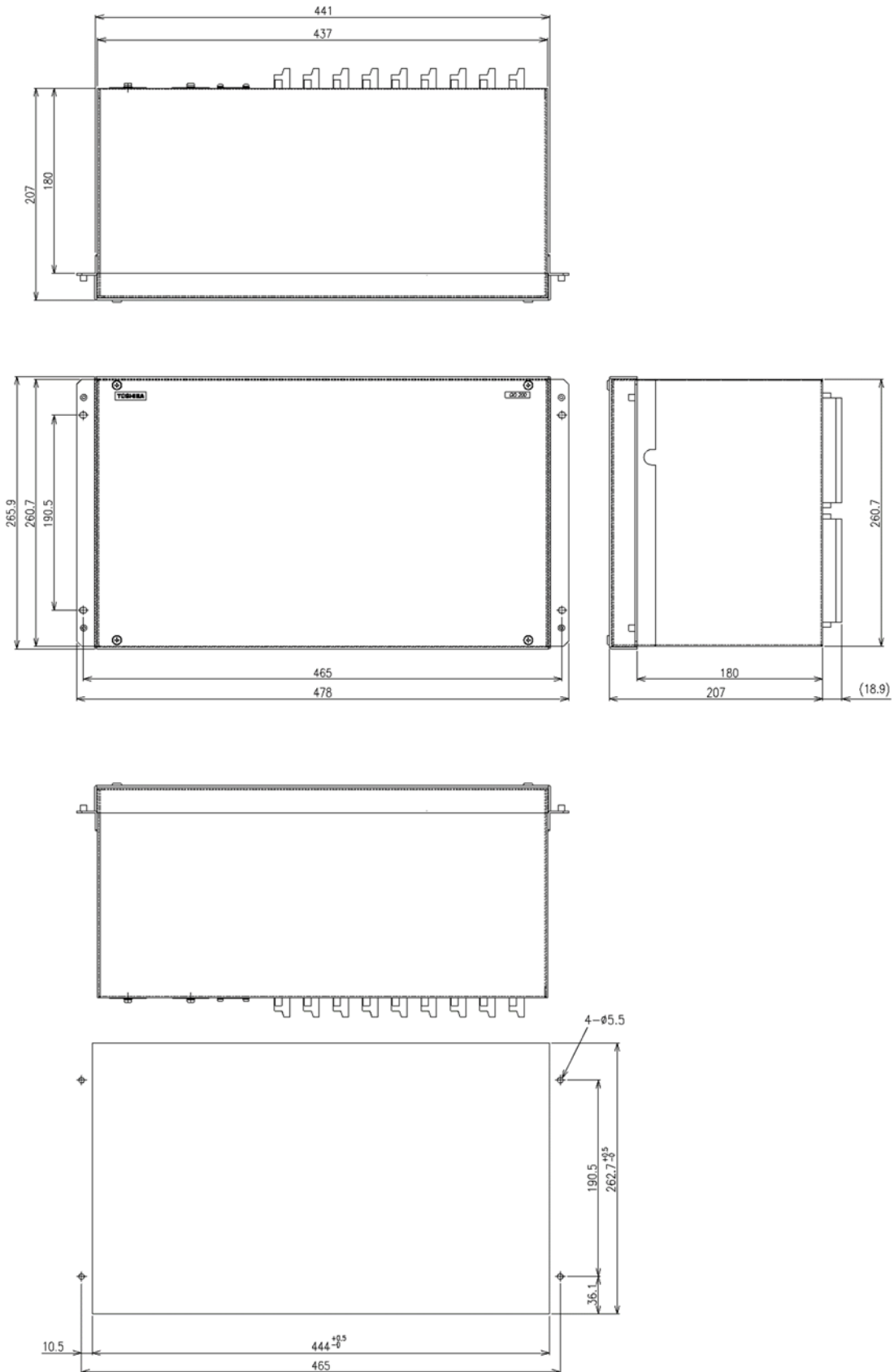

Figure 17 – Dimension and Panel Cut-out – 1/1 x 19” case size

TOSHIBA

TOSHIBA ENERGY SYSTEMS & SOLUTIONS CORPORATION

72-34, Horikawa-cho, Saiwai-ku, Kawasaki 212-8585, Japan
Tel +81-44-331-1462 Fax +81-44-548-9540
<http://www.toshiba-relays.com>

- The information given in this catalog is subject to change without notice.
- The information given in this catalog is as of 30 July 2020
- The information given in this catalog is presented only as a guide for the applications of our products. No responsibility is assumed by TOSHIBA for any infringements of patents or other rights of the third parties which may result from its use. No license is granted by implication or otherwise under any patent or patent rights of TOSHIBA or others.
- TOSHIBA products should not be embedded to the downstream products which are prohibited to be produced and sold, under any law and regulations.
- Toshiba does not take any responsibility for incidental damage (including loss of business profit, business interruption, loss of business information and other pecuniary damage) arising out of the use or disability to use the products.